



# C A T A L O G

2 0 2 5

So **light**

So **adjustable**

So **sustainable**



**INTRODUCTION..... 02**

- Company profile
- Sustainability

**EXHIBITION AND STORE SETUP..... 06**

- Clothing and accessories
- Stationery
- Food & beverage
- Gift & design
- Toy

**DISPLAYS .....11**

- Counter
- Floor
- Adjustable
- Tables
- Rotating

**CUSTOMER REVIEWS ..... 82**



# WELCOME TO ESPOSIT NEW CATALOGUE

Today, I would like to tell you a story- don't worry, it's a short one. Have you ever wondered how an interlocking product comes to life?

I asked myself this question a few years ago when I was in a woodworking shop, observing birch panels.

As I watched them, stacked one on top of the other, I wondered how we would be able to create a furniture line using interlocking wood panels.

A design line with the characteristics of an industrial production, infinitely replicable.

This is the most distinctive and remarkable feature of our interlocking products: although they are three-dimensional, their design originates from a two-dimensional arrangement on a wooden panel.

We join panels together.

We think in 2D to create 3D products.

We like to think that interlocking products are always the same, yet the difference lies in how the pieces are assembled to achieve an extraordinary result: a unique and meticulously crafted product.

This is how Esposit, leading brand by the Saglietti Group, was born and it has for years been involved in enhancing and showcasing our clients' products in the best way possible.

The wide range of display furniture and experiential corners you will find on the following pages offers a modern interpretation of the Esposit exhibition concept.

All our furniture is the result of careful design that provides an eco-friendly solution using the interlocking technique.

Esposit is simple, lightweight, and sustainable.

A design line that meets our customers' needs, offering customised, sustainable, and long-lasting furniture. Our furniture can be assembled and disassembled even by unskilled personnel, and it can be easily transported thanks to its flat pack design.

We hope we could pique your curiosity and invite you to take a look around the other pages of our catalogue: our doors are always open to welcome everyone.

We look forward to seeing you!

Welcome to the new Esposit catalogue!

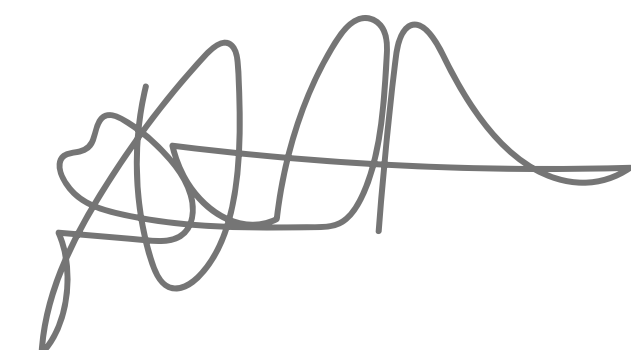

## SUSTAINABILITY AT THE HEART OF OUR COMMITMENT

In the production of Esposit line products, we are committed to reducing our environmental impact through the use of certified materials and cutting-edge manufacturing technologies. All our displays are crafted from wood sourced from sustainable forests, ensuring a controlled supply chain that meets FSC® (Forest Stewardship Council) certification standards.

Furthermore, we invest in production processes that minimize waste in our operations and prioritize the use of non-toxic paints and finishes with emissions next to zero. Every Esposit product is designed to be durable and recyclable, promoting sustainable practices at scale for long-term impact.

Our goal is to combine innovative design and environmental responsibility, offering display solutions that not only enhance products but also contribute to a more sustainable future. With Esposit, you choose a partner that places environmental sustainability at the heart of every creation.



## CLOTHING AND ACCESSORY RACKS & DISPLAYS

Display your clothing collection impeccably with our adjustable wooden displays. These versatile displays are the perfect choice for fashion shops, offering a blend of elegance and functionality.

The natural beauty of wood adds warmth and style, enhancing your product presentation both in-store and at trade fairs. With a range of adjustable features, you can customize the display to showcase clothing, shoes, and accessories, ensuring that each item is very attractively presented and remains easily accessible. Your customers will appreciate the opportunity to see the product details clearly while enjoying the aesthetic appeal of the wooden display- always enforcing our claim for sustainability.

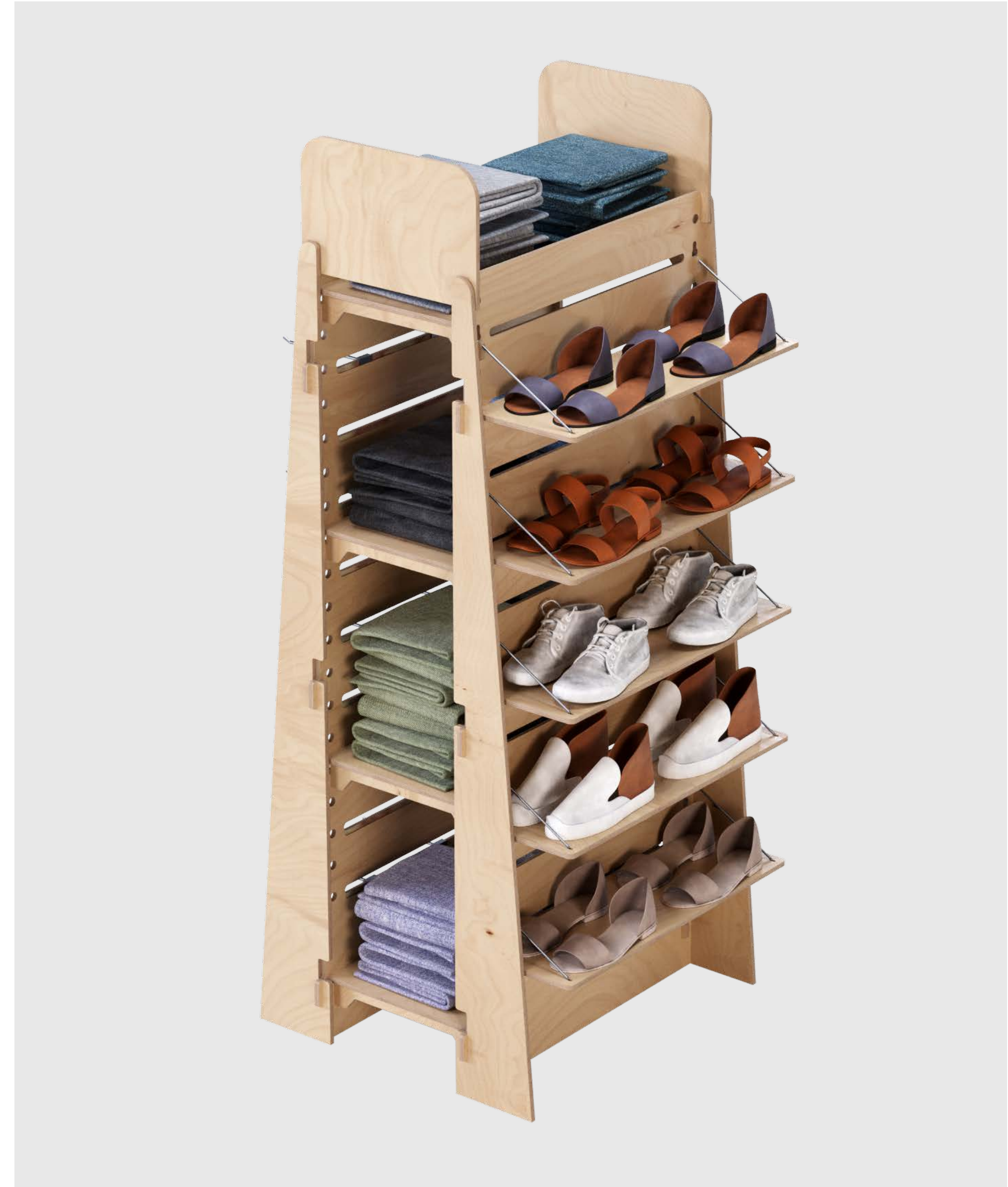
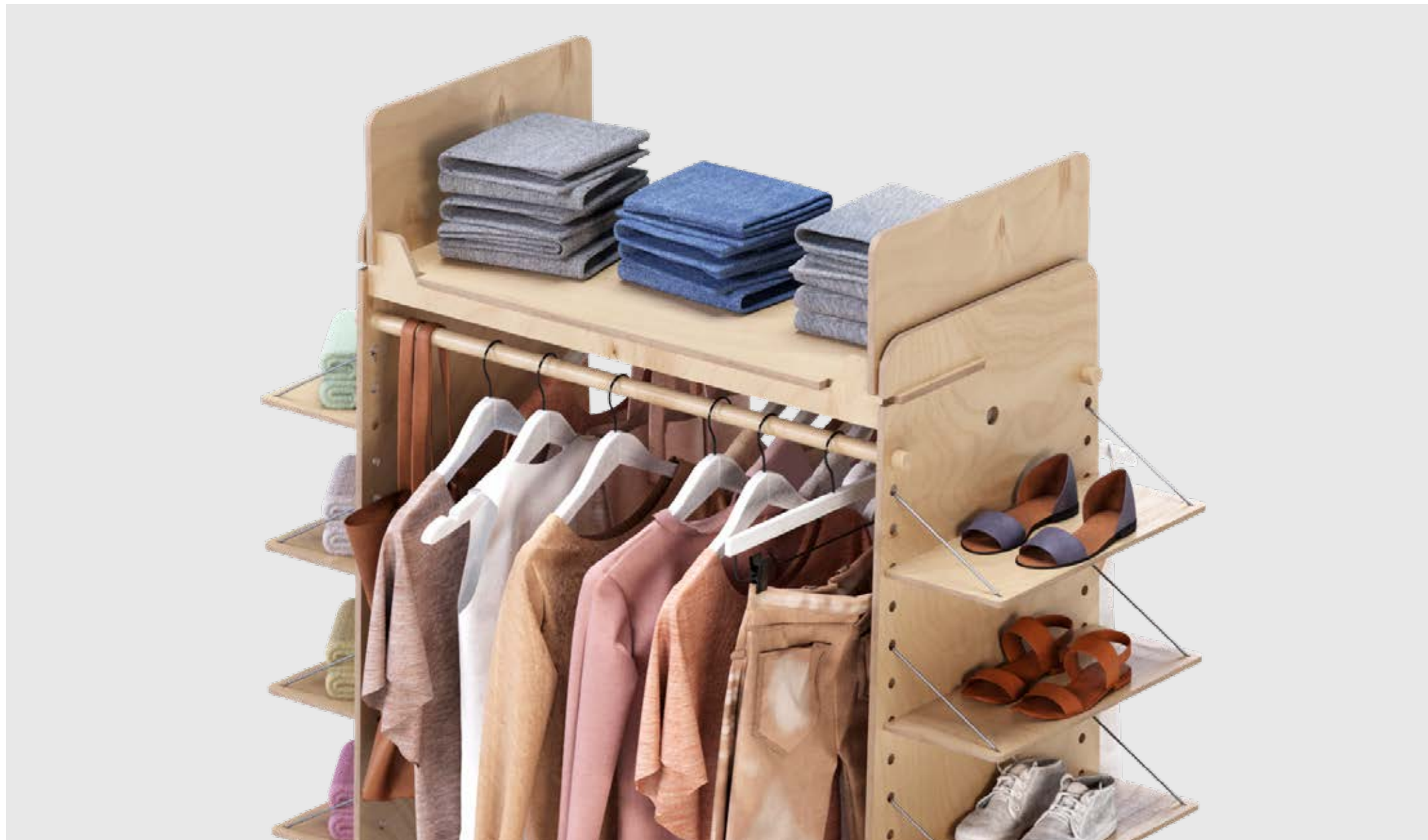

So **light**  
 So **adjustable**  
 So **sustainable**

## STATIONERY AND LITERATURE HOLDERS & DISPLAYS

Our adjustable wooden stationery and literature displays are an excellent choice, combining the wood's natural beauty with the versatility of an adjustable design. These holders are perfect for showcasing pens, notebooks, diaries, and other stationery items in a neat and appealing manner. The warm tones of the wood add a touch of elegance and natural beauty, while the adjustable height and customizable shelf arrangement make them suitable for items of various size. They provide an organized and inviting shopping experience for your customers.

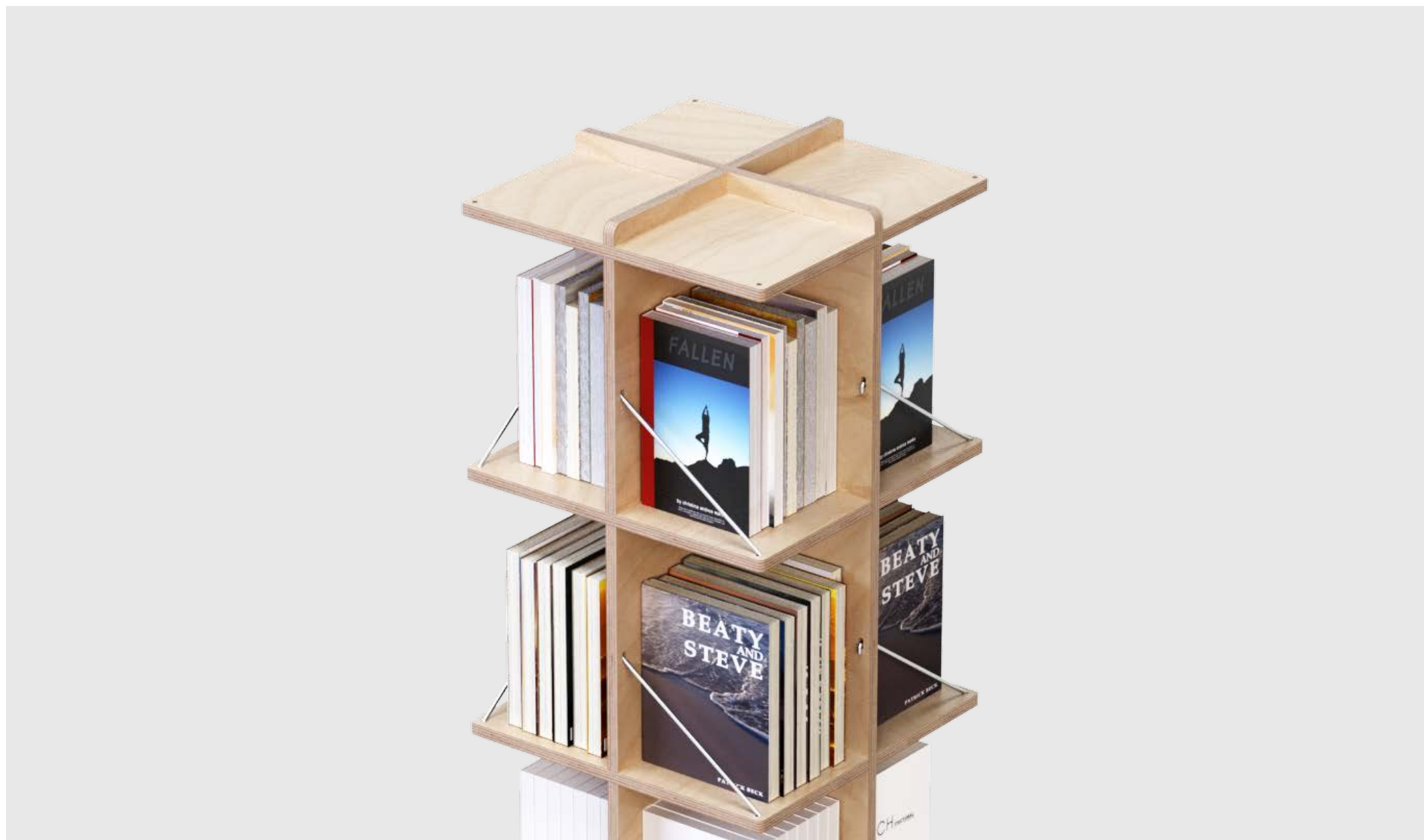

So **light**  
 So **adjustable**  
 So **sustainable**

## FOOD & BEVERAGE DISPLAY RACKS

When it comes to food and beverages, presentation is key. Our adjustable wooden displays bring a touch of elegance and sophistication to the shopping experience. The natural wood creates a warm and inviting atmosphere, making it ideal for showcasing high-quality gastronomic products. Whether it's the simplest loaf or the most sumptuous wine, these displays provide an elegant space to present your products.

With adjustable shelves, you can easily showcase food and beverages of various sizes and shapes, providing an appealing presentation and an easy to use solution. The use of wood adds a sense of authenticity that perfectly complements artisanal and gourmet products.



So **light**  
 So **adjustable**  
 So **sustainable**



## MERCHANDISING & GIFT SHOP DISPLAY FIXTURES

Our adjustable wooden displays for the Merchandising and Gift Shop category bring a touch of elegance and modernity to the shopping experience.

The natural wood conveys a sense of authenticity and craftsmanship, perfectly suited for a category where aesthetics is paramount.

These adjustable wooden displays are the ideal choice for showcasing unique art pieces, gifts, and design products.

Designed to accommodate objects of various shapes and sizes, they create a sophisticated and contemporary display space that inspires and delights customers.



So **light**  
So **adjustable**  
So **sustainable**

## TOY & GAMES DISPLAY STANDS

Children and families will be captivated by our adjustable wooden toy and games display stands.

The natural wood creates a warm and playful atmosphere, making the shopping experience even more enjoyable.

Thanks to their modular design, these displays allow you to efficiently organize a variety of toys and games in different shapes and sizes, adding a touch of natural charm and familiarity.

Offer your customers a memorable and sustainable shopping experience!



So **light**  
So **adjustable**  
So **sustainable**

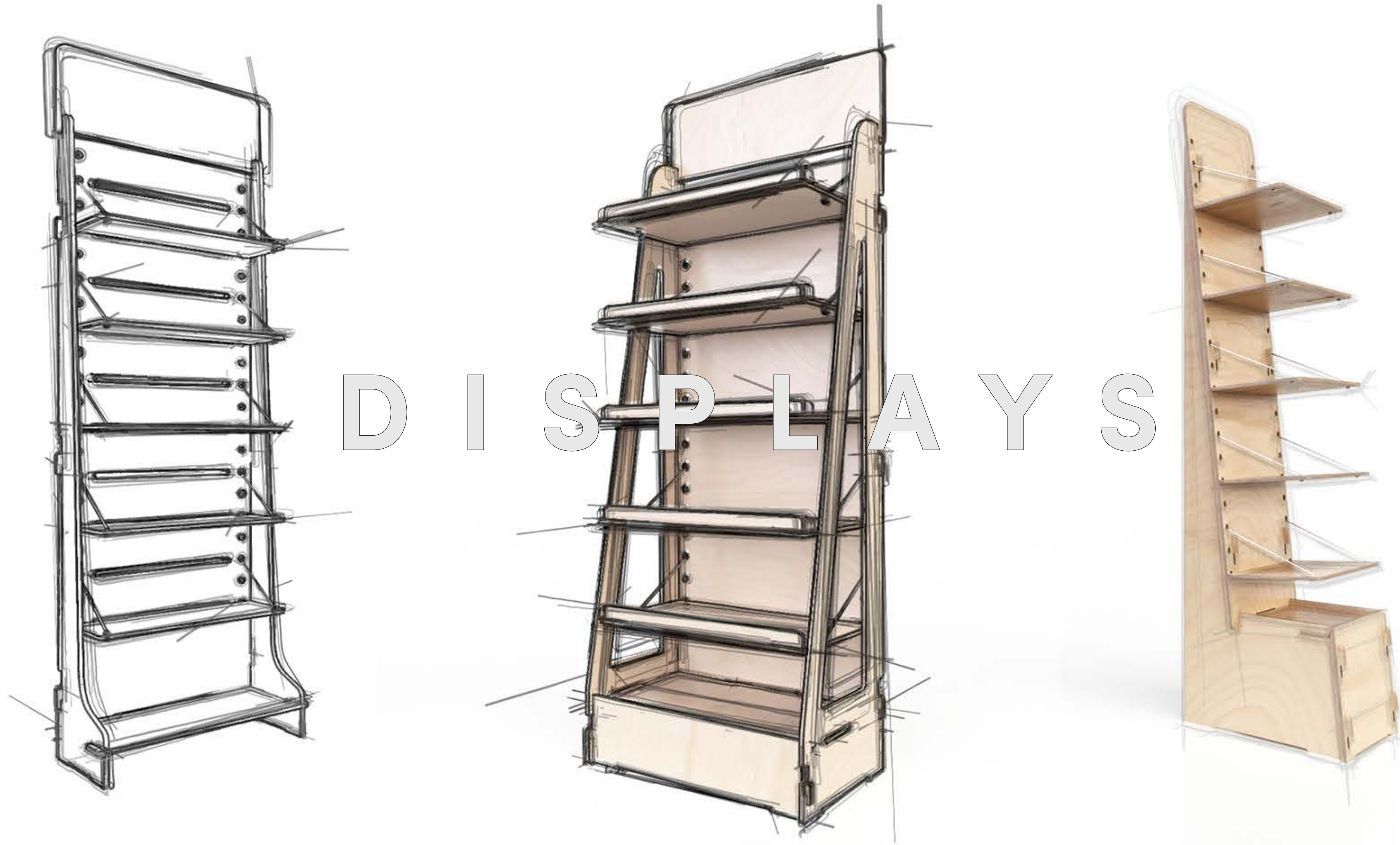

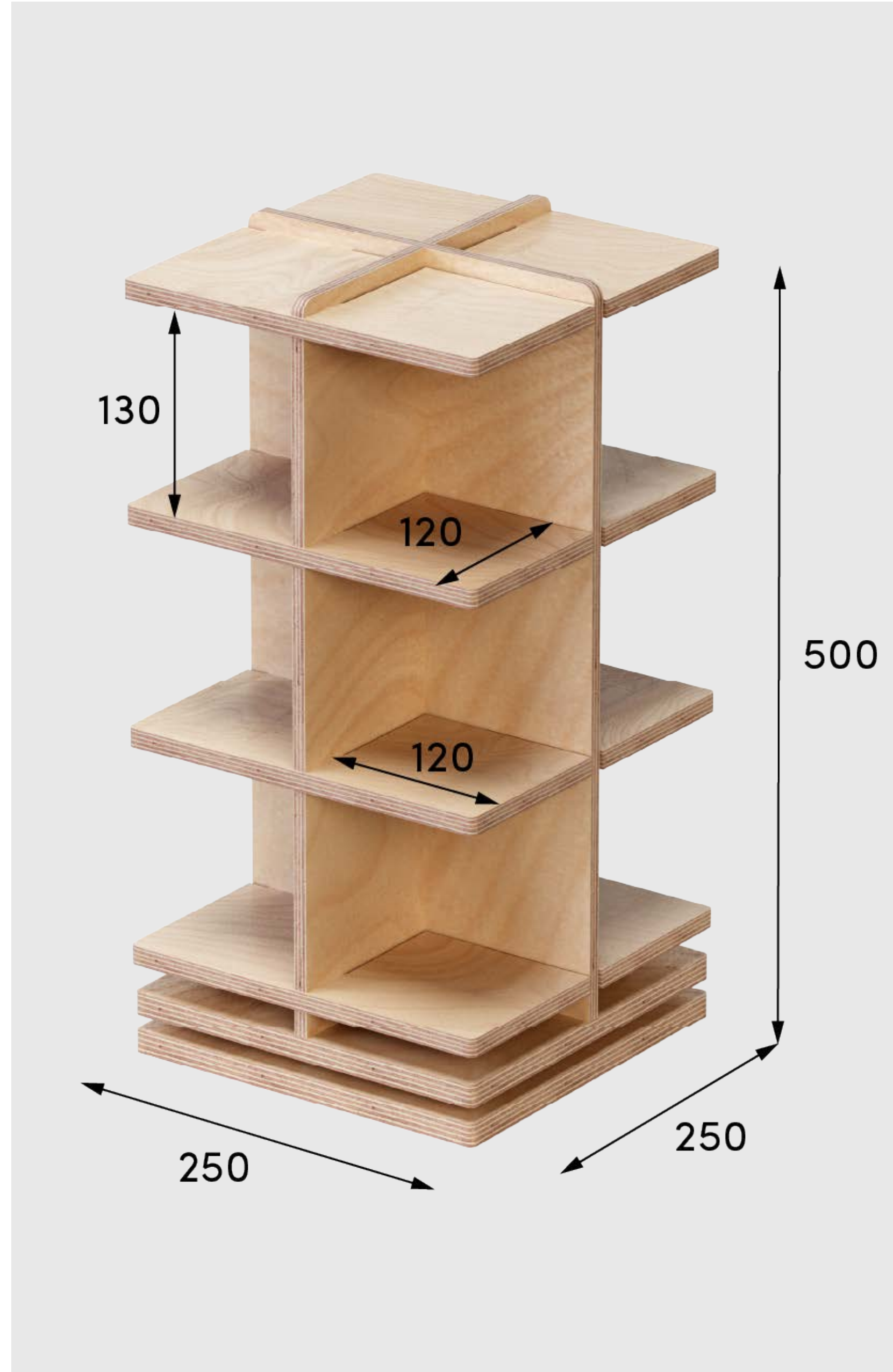
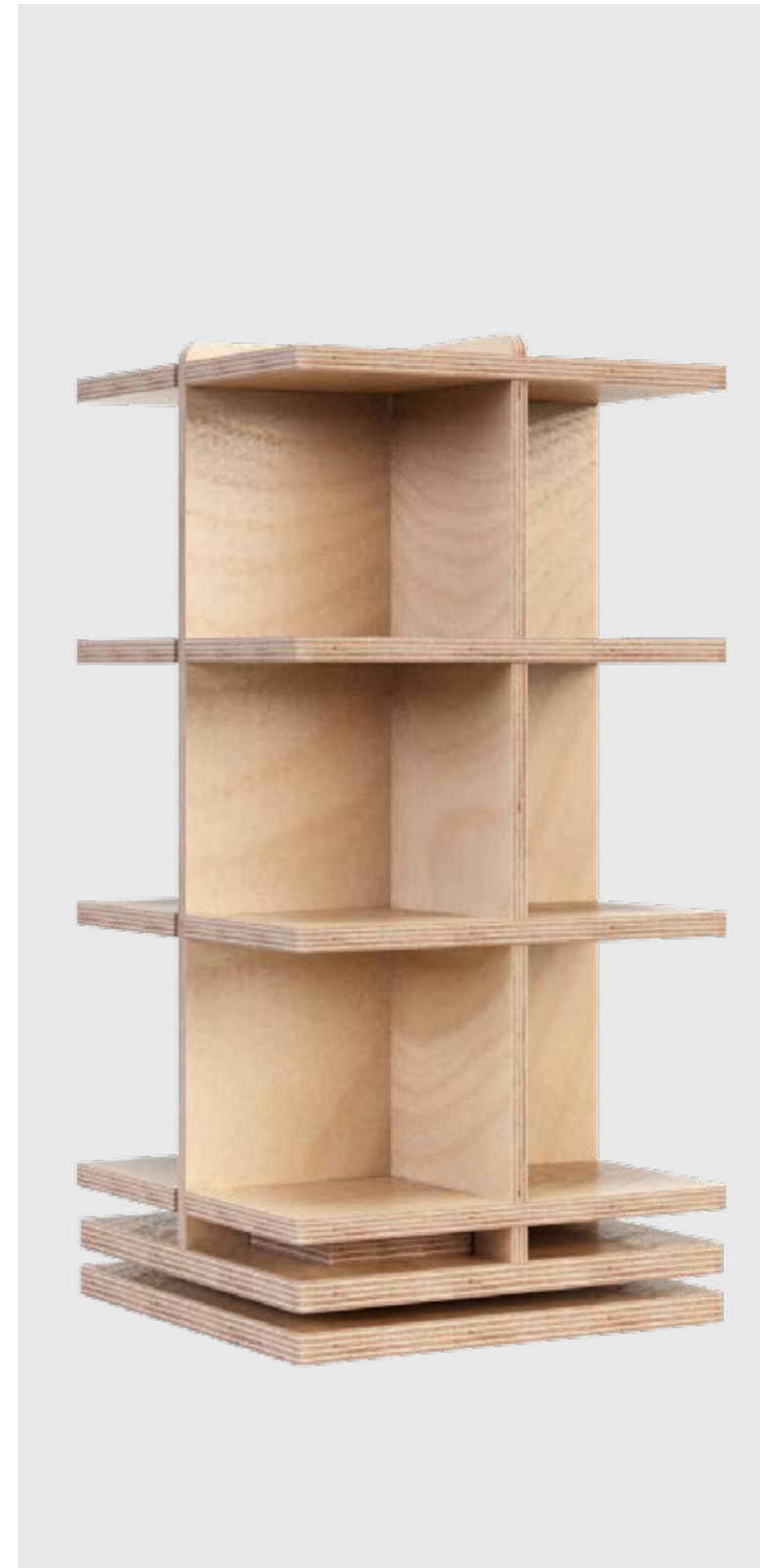

## Bix

The Bix Revolving Counter Display is the perfect choice for presenting your products in an eco-friendly and professional way. With its innovative, rotating design, it's ideal for showcasing books and other stationery items like greeting cards or planners. It's also a great fit for displaying gift products like mugs or packaged snack foods.

Crafted from wood sourced from FSC-certified sustainable forests, this display stand offers a responsible solution to highlight and promote your brand. Its quick snap-fit assembly requires minimal effort, saving you valuable time. Plus, its lightweight construction makes it easy to transport and place anywhere you want.

**Material:**

- Eucalyptus 9-15 mm

**Weight:**

15 kg

**Package (WxDxH):**

160x45x6 cm

**Customization:**

- Painting
- Graphic printing

So **light**  
So **adjustable**  
So **sustainable**



# Pluma

A compact counter display designed for small items, this is one of Esposit's best selling products. Here's why:

- Perfect for retail outlets with limited space available.
- Significant storage space while maintaining a small footprint.
- Mini showcase ideal for trade shows or events.
- Elegant and eco-friendly thanks to the use of sustainable wood and a smart joint system.

Multiple units are conveniently shipped in a single package for added efficiency.

**Material:**  
- Eucalyptus 4-9 mm

**Weight:**  
1,3 kg

**Package (WxDxH):**  
42x32x5 cm

**Customization:**  
- Painting  
- Graphic printing

So **light**  
So **adjustable**  
So **sustainable**

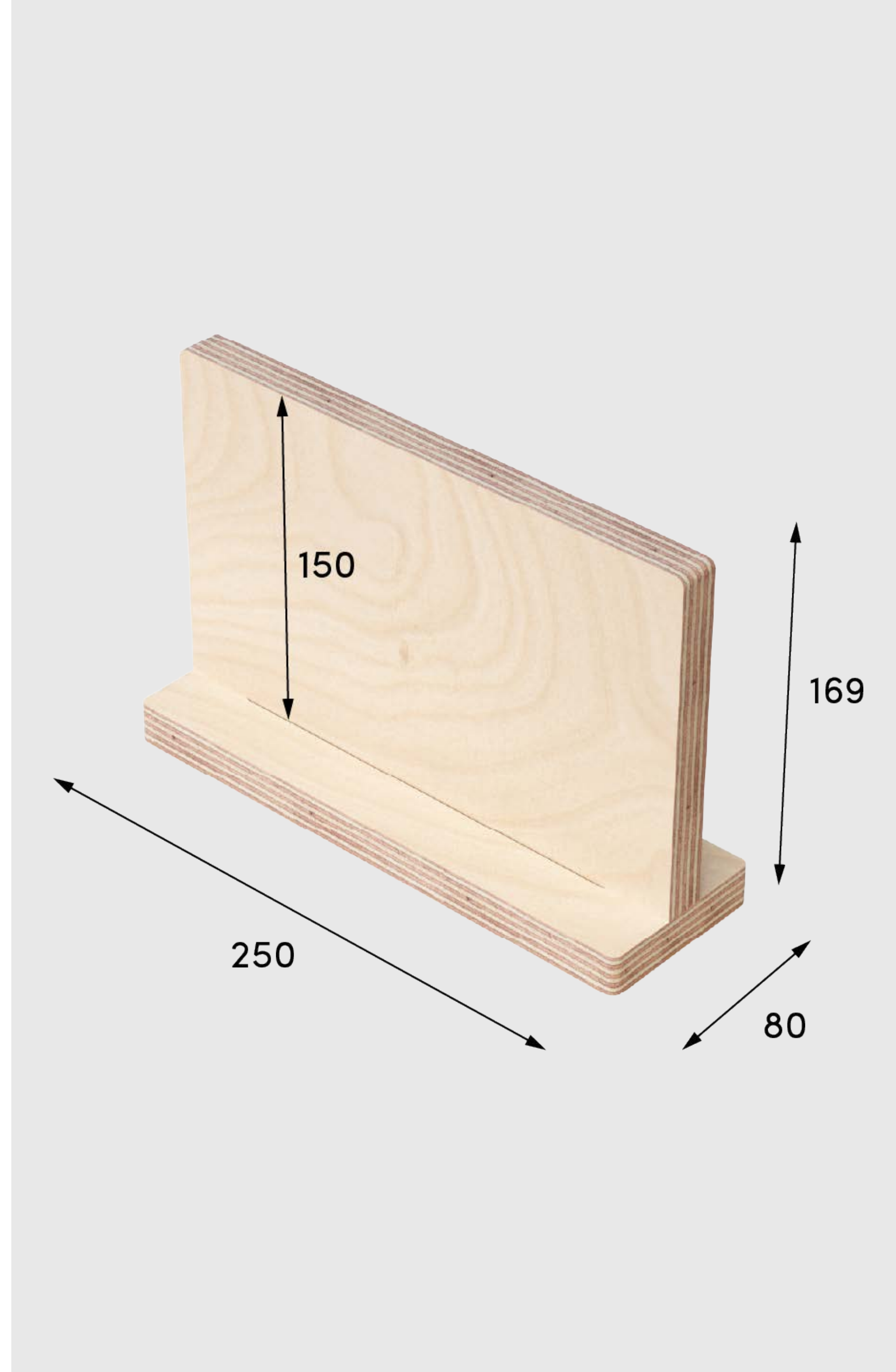

## Enix

Minimal and Elegant Design,  
Perfect for Showcasing Countertop  
Products.

Crafted from FSC-certified wood  
sourced from sustainable forests, this  
display provides an eco-friendly and  
stylish way to promote your brand.

With its quick interlocking assembly,  
it's incredibly easy to set up, saving  
you time and effort. Plus, the  
lightweight wooden structure makes  
it simple to transport and place  
wherever it's needed.

**Material:**

- Eucalyptus 18 mm

**Weight:**

0,7 kg

**Customization:**

- Painting
- Graphic printing

So **light**  
So **adjustable**  
So **sustainable**



## Flag Cellar

Portable Wine Rack with a 20-Bottle Capacity.

Compact and elegant, this wine rack is the perfect solution for displaying wine bottles on a table or countertop. Ideal for retail outlets with limited space, it also serves as a sophisticated showcase for exhibition stands.

Crafted from FSC-certified wood sourced from sustainable forests, this display offers an eco-friendly way to present and promote your brand. With its quick interlocking assembly, it requires minimal effort to set up, saving you valuable time. Plus, the lightweight wooden structure makes it easy to transport and position wherever it is needed.

**Material:**

- Eucalyptus 9 mm

**Weight:**

10 kg

**Package (WxDxH):**

100x50x5 cm

**Customization:**

- Painting
- Graphic printing

So **light**  
So **adjustable**  
So **sustainable**



## Banco 2

Compact Two-Tier Counter Display for Small Items.

Designed for retail spaces with limited room, this display provides ample storage space while maintaining a small footprint. It also works perfectly as an elegant and compact showcase at exhibition stands.

Crafted from FSC-certified wood sourced from sustainable forests, this display offers an eco-friendly and stylish way to present and promote your brand. Its quick interlocking assembly requires minimal effort, saving you valuable time. Plus, the lightweight wooden structure makes it easy to transport and place wherever it's needed.

**Material:**

- Eucalyptus 4-9 mm

**Weight:**

3,8 kg

**Package (WxDxH):**

52x50x4 cm

**Customization:**

- Painting
- Graphic printing

So **light**  
So **adjustable**  
So **sustainable**

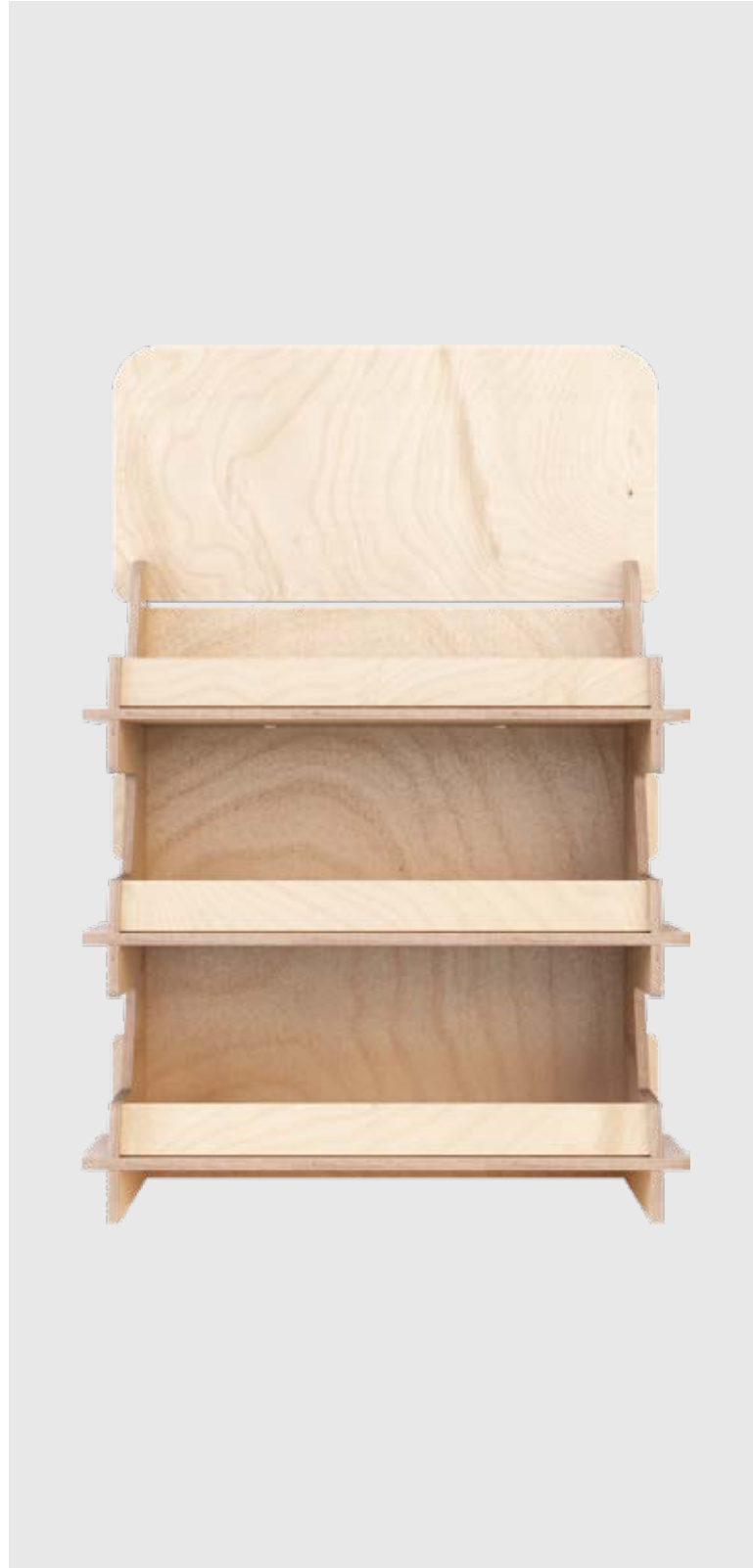

## Banco 3

Compact Three-Tier Counter Display for Small Items

Perfect for retail spaces with limited room, this display offers a generous amount of storage space while maintaining a sleek and compact size. It also serves as a stylish and practical showcase for exhibition stands, making your products stand out more and more.

Crafted from FSC-certified wood sourced from sustainable forests, this display provides an eco-friendly and elegant way to promote your brand. With its quick interlocking assembly, it requires minimal effort to set up, saving you time and hassle. Plus, the lightweight wooden structure makes it easy to transport and position wherever it is needed.

**Material:**

- Eucalyptus 4-9 mm

**Weight:**

4,5 kg

**Package (WxDxH):**

52x50x4 cm

**Customization:**

- Painting
- Graphic printing

So **light**  
So **adjustable**  
So **sustainable**

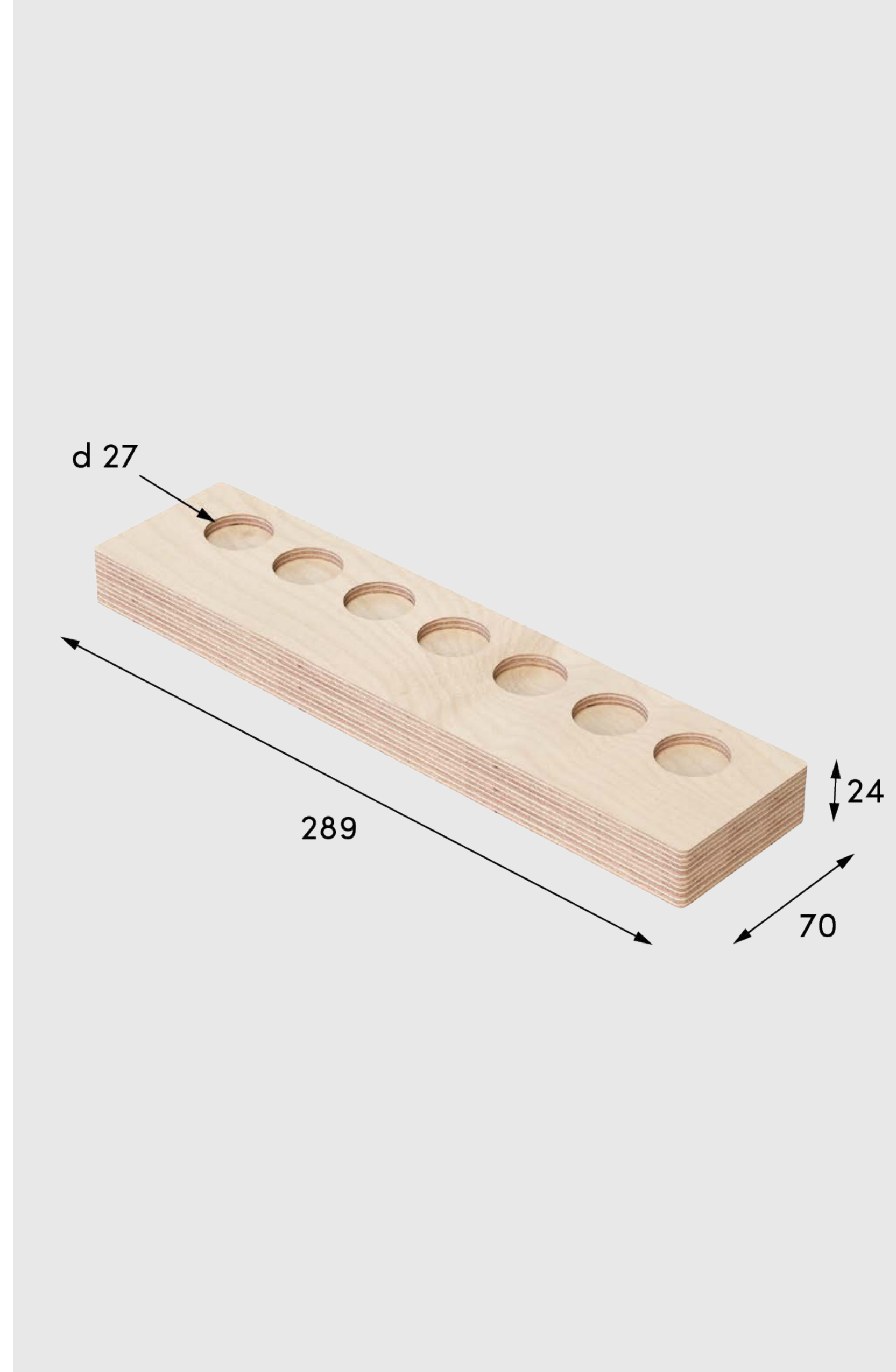
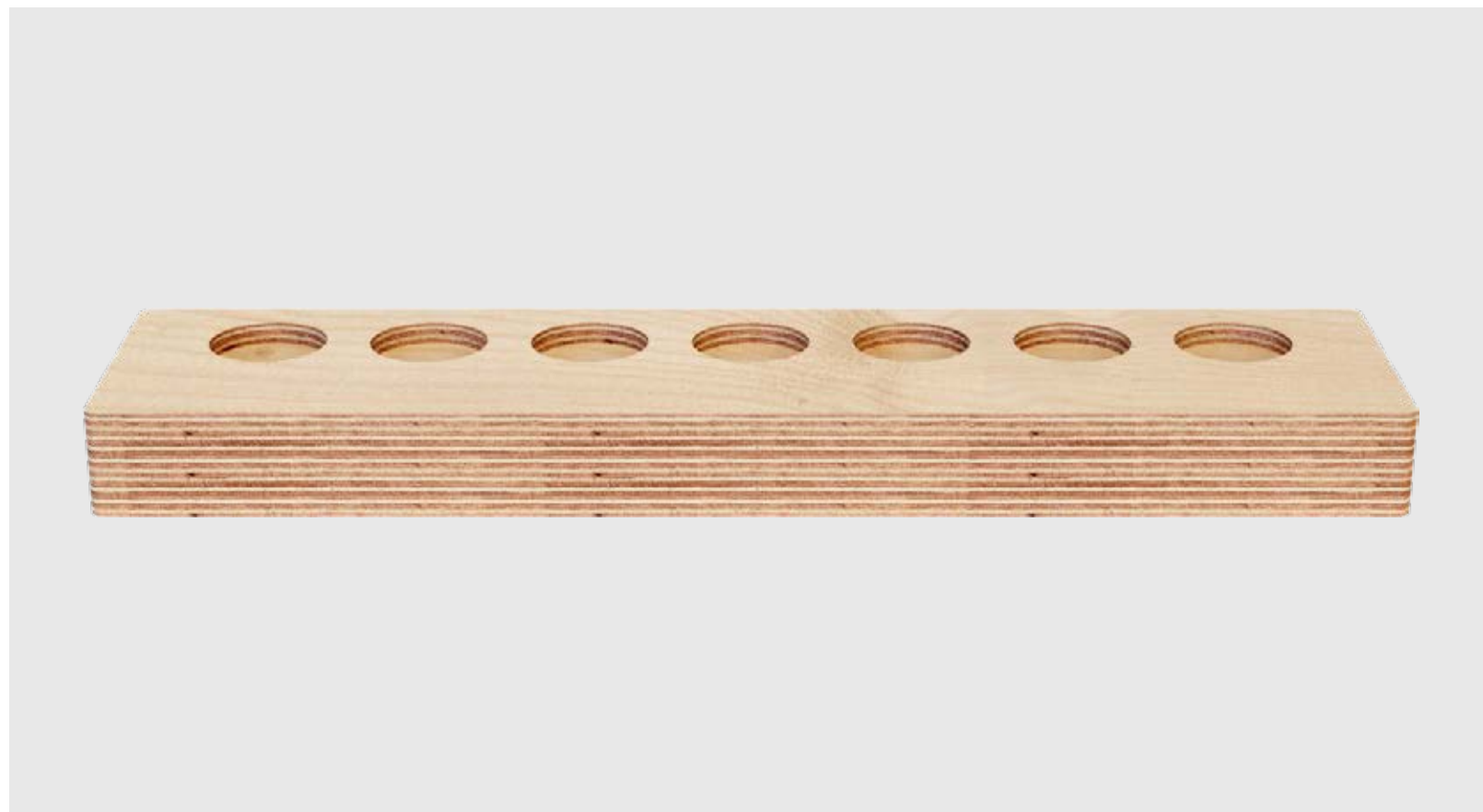

## Fyra

Compact Three-Tier Counter Display for Small Items.

Designed for retail spaces with limited room, this display provides ample storage space while maintaining a sleek and compact size. It's also an excellent choice for exhibition stands, serving as a small yet stylish showcase for your products.

Crafted from FSC-certified wood sourced from sustainable forests, this display provides an eco-friendly and responsible way to present and promote your brand.

**Material:**

- Eucalyptus 18 mm

**Weight:**

0,4 kg

**Package (WxDxH):**

30x10x4 cm

**Customization:**

- Painting
- Graphic printing

So **light**  
So **adjustable**  
So **sustainable**

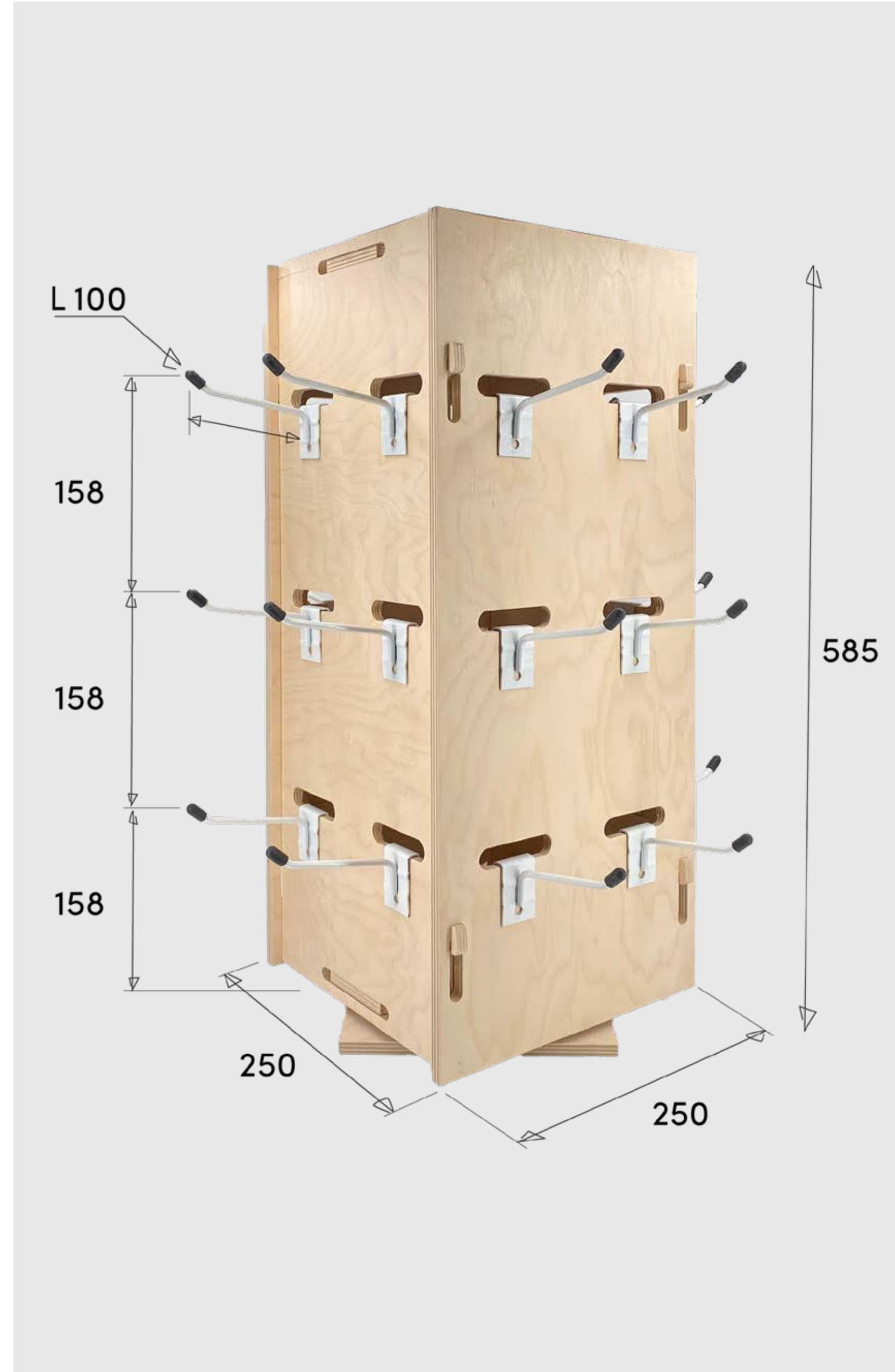
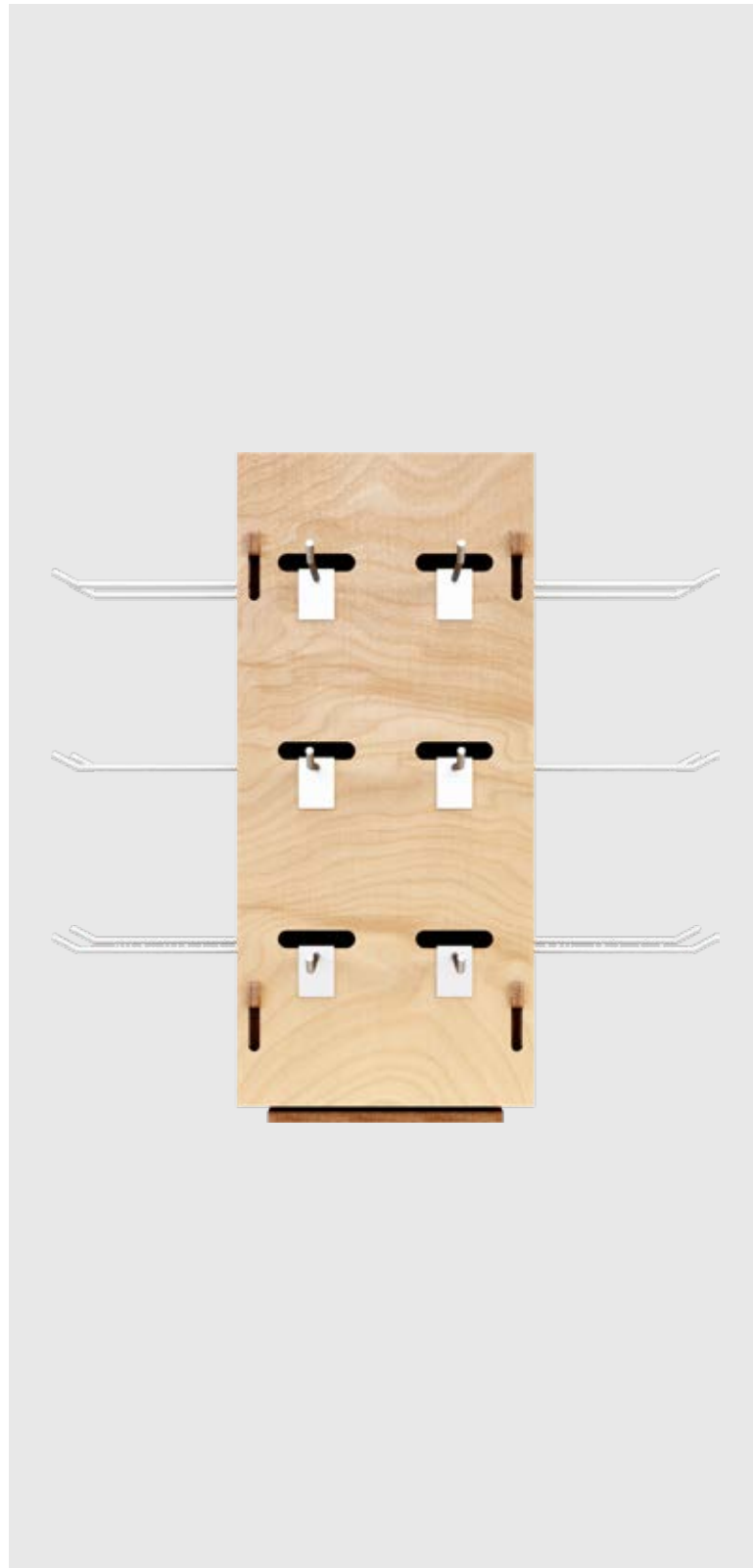

## Girevole Banco

Innovative Rotating Display – Perfect for Products in Blister  
Featuring a sleek and rotating design, this display is the ideal solution for showcasing blister-packed products offering maximum visibility.

Crafted from FSC-certified wood sourced from sustainable forests, it offers an eco-friendly and responsible way to promote your brand. With its quick interlocking assembly, the setup process requires minimal effort, saving you valuable time. Plus, the lightweight wooden structure makes it easy to transport and place wherever it's needed.

**Material:**

- Eucalyptus 9 mm
- 24 ganci bianchi da 10cm

**Weight:**

4 kg

**Package (WxDxH):**

65x30x9 cm

**Customization:**

- Painting
- Graphic printing

So **light**  
So **adjustable**  
So **sustainable**



## Levia

The Levia Stand is the perfect choice for presenting your products in a sustainable and qualitative way. With its compact design and practical shelves, it's ideal for displaying small boxes, jars, candies, chocolate bars, and other small-sized items.

Crafted from wood sourced from FSC-certified sustainable forests, this display stand provides an eco-friendly way to showcase and promote your brand. Its quick snap-fit assembly requires minimal effort, saving you valuable time. Plus, its lightweight wooden construction makes it easy to transport and position wherever you need it.

**Material:**

- Eucalyptus 4-9 mm

**Weight:**

4,5 kg

**Package (WxDxH):**

52x50x4 cm

**Customization:**

- Painting
- Graphic printing

So **light**  
So **adjustable**  
So **sustainable**

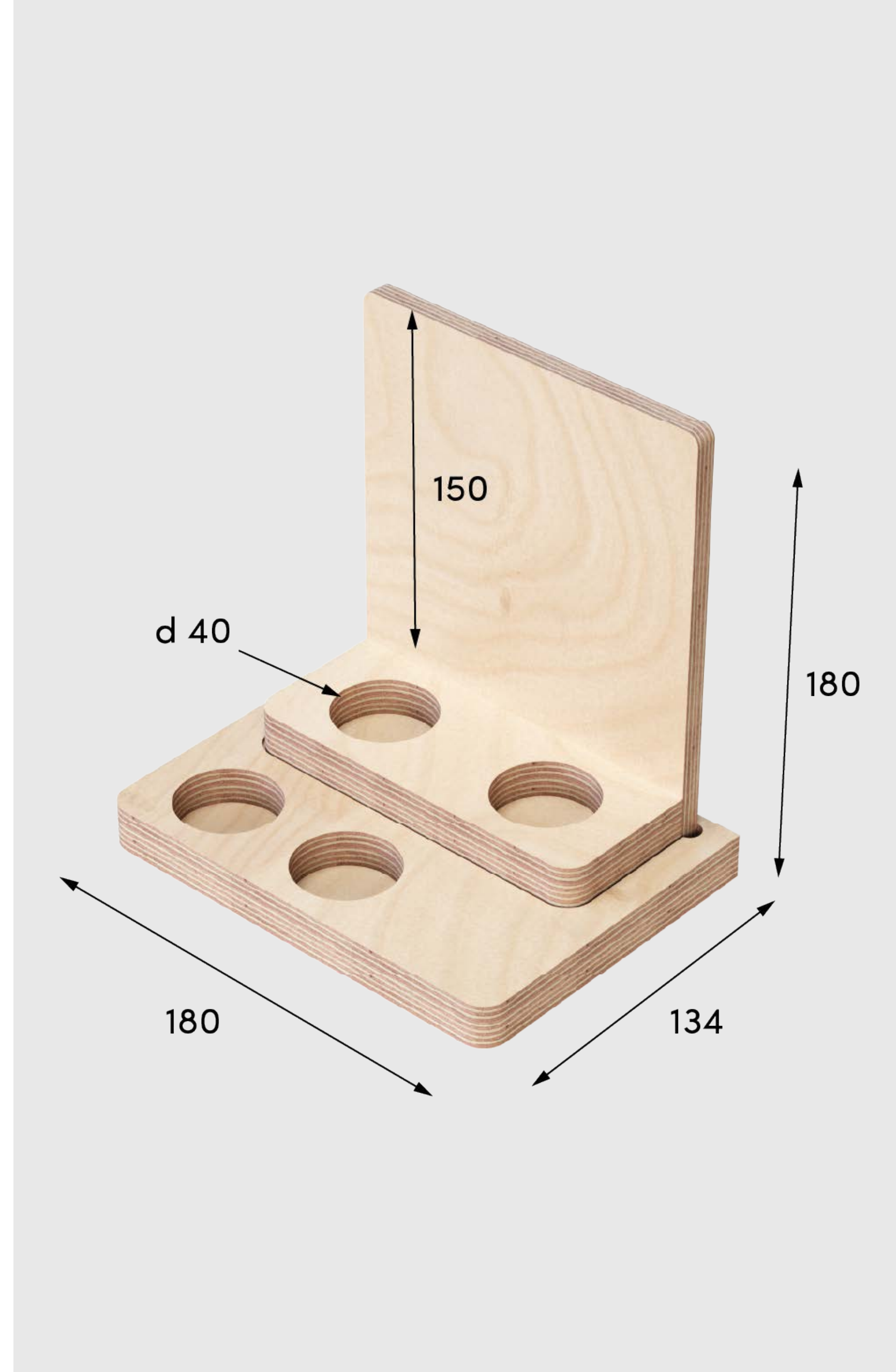

## Nexo

The Nexo Counter Stand is an excellent choice for presenting your products in a sustainable and professional way. With its minimalist design and subtle print, it's ideal for showcasing essential oils and fragrances. It also works perfectly for cosmetics, lotions, perfumes, and other personal care products.

Crafted from wood sourced from FSC-certified sustainable forests, this display stand offers an eco-friendly and responsible way to promote your brand. Its quick snap-fit assembly requires minimal effort, saving you valuable time and effort. Plus, its lightweight wooden construction makes it easy to transport and place wherever it's needed.

**Material:**

- Eucalyptus 9-18 mm

**Weight:**

0,6 kg

**Package (WxDxH):**

30x20x4 cm

**Customization:**

- Painting
- Graphic printing

So **light**  
So **adjustable**  
So **sustainable**

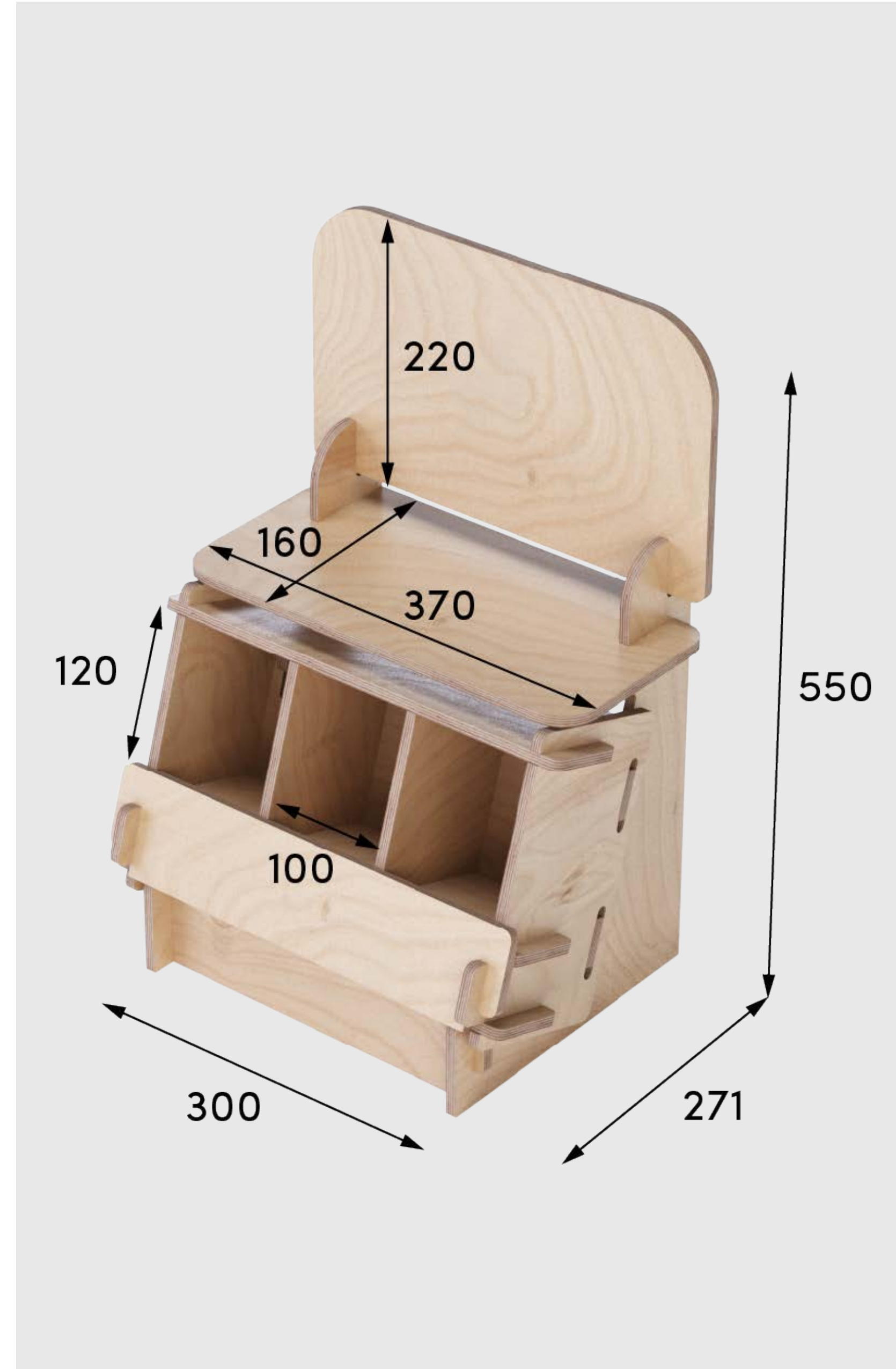

## Sfusino

Highly Effective Counter Display  
– Ideal for Closed Packaging and Loose Products

Crafted from FSC-certified wood sourced from sustainable forests, this display provides an eco-friendly and responsible way to showcase and promote your brand. Its versatile design makes it perfect for presenting both closed packaging and loose products, offering maximum visibility and best product protection. With an easy interlocking assembly, setup requires minimal effort, saving you valuable time. Plus, the lightweight wooden structure makes it simple to transport and provides flexible placement options to suit your needs.

**Material:**

– Eucalyptus 9 mm

**Weight:**

3,4 kg

**Package (WxDxH):**

52x34x4 cm

**Customization:**

- Painting
- Graphic printing

So **light**  
So **adjustable**  
So **sustainable**



## Step 2

The Step 2 Counter Display is the perfect choice for presenting your products in a sustainable and qualitative way. Its compact design makes it ideal for showcasing small boxes and jars, as well as candies, chocolate bars, and other small-sized items.

Crafted from wood sourced from FSC-certified sustainable forests, this display stand offers an eco-friendly and responsible way to promote your brand. With a quick snap-on mounting system, it requires a minimum of effort to set up, saving you valuable time. Plus, its lightweight wooden construction makes it easy to transport and position wherever you need it.

**Material:**

- Eucalyptus 9 mm

**Weight:**

1,1 kg

**Package (WxDxH):**

42x32x5 cm

**Customization:**

- Painting
- Graphic printing

So **light**  
So **adjustable**  
So **sustainable**

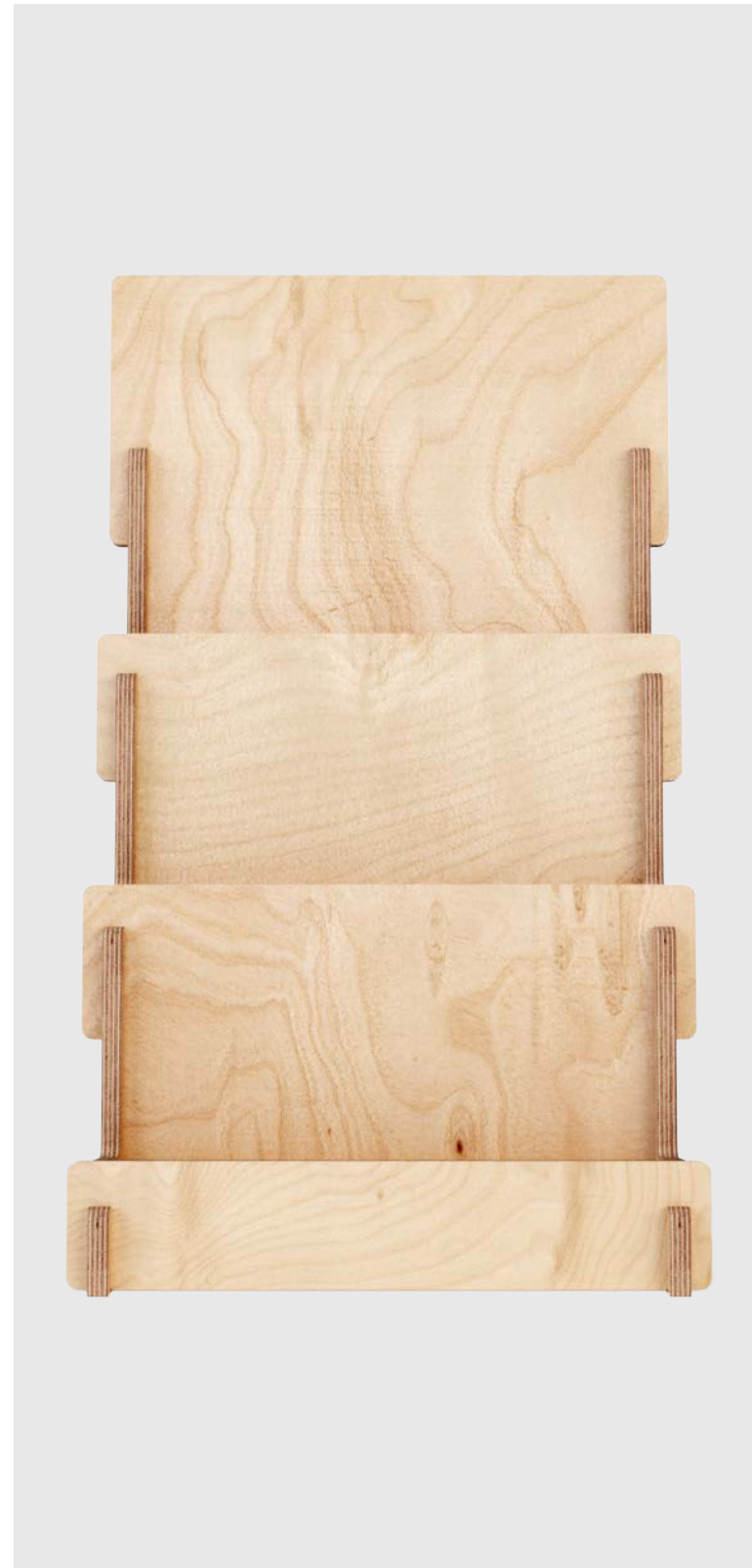

### Step 3

The Step 3 Counter Display is the perfect choice for presenting your products in a sustainable and efficient way. Its compact design and practical shelves make it ideal for displaying small boxes and jars, as well as candies, chocolate bars, and other small-sized items.

Crafted from wood sourced from FSC-certified sustainable forests, this display stand offers an eco-friendly and stylish way to showcase and promote your brand. With a quick snap-fit assembly, it requires minimal effort to set up, saving you valuable time. Plus, its lightweight wooden construction makes it easy to transport and position wherever you need it.

**Material:**

- Eucalyptus 9 mm

**Weight:**

1,6 kg

**Package (WxDxH):**

42x32x5 cm

**Customization:**

- Painting
- Graphic printing

So **light**  
So **adjustable**  
So **sustainable**

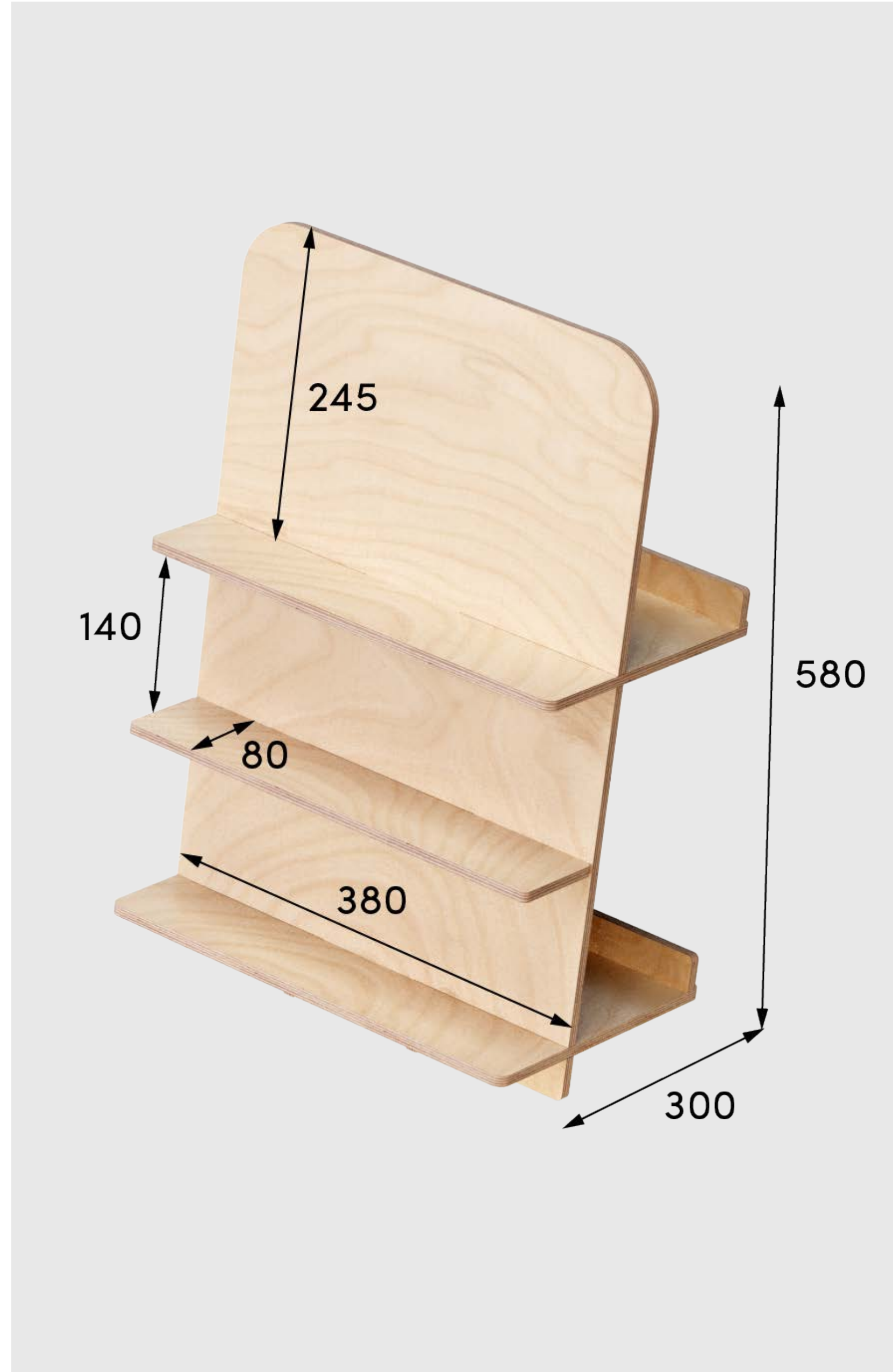

## Wes

Perfect for Displaying Wallets and Small Leather Accessories  
 Crafted from FSC-certified wood sourced from sustainable forests, this display provides an eco-friendly solution to showcase and promote your brand.

Assembly is also quick and easy, thanks to the interlocking system without the use of special tools. Plus, the lightweight wooden structure makes it easy to transport and position wherever it's needed. Designed with both style and functionality in mind, it's the ideal choice for presenting wallets, small leather goods, and other premium accessories.

**Material:**

- Eucalyptus 9 mm

**Weight:**

3 kg

**Package (WxDxH):**

65x45x4 cm

**Customization:**

- Painting
- Graphic printing

So **light**  
 So **adjustable**  
 So **sustainable**



## Delt

With its minimal footprint and elegant design, this display system is ideal for showcasing essential oils and fragrances. It's also perfect for presenting cosmetics, creams, perfumes, and other personal care products.

Crafted from FSC-certified wood sourced from sustainable forests, this display offers an eco-friendly, new and unique way to promote your brand.

The easy interlocking assembly ensures quick and effortless setup, saving you valuable time. Plus, its lightweight wooden construction makes it easy to transport and position wherever it's needed.

**Material:**

- Eucalyptus 9-18 mm

**Weight:**

1 kg

**Package (WxDxH):**

30x30x4 cm

**Customization:**

- Painting
- Graphic printing

So **light**  
So **adjustable**  
So **sustainable**

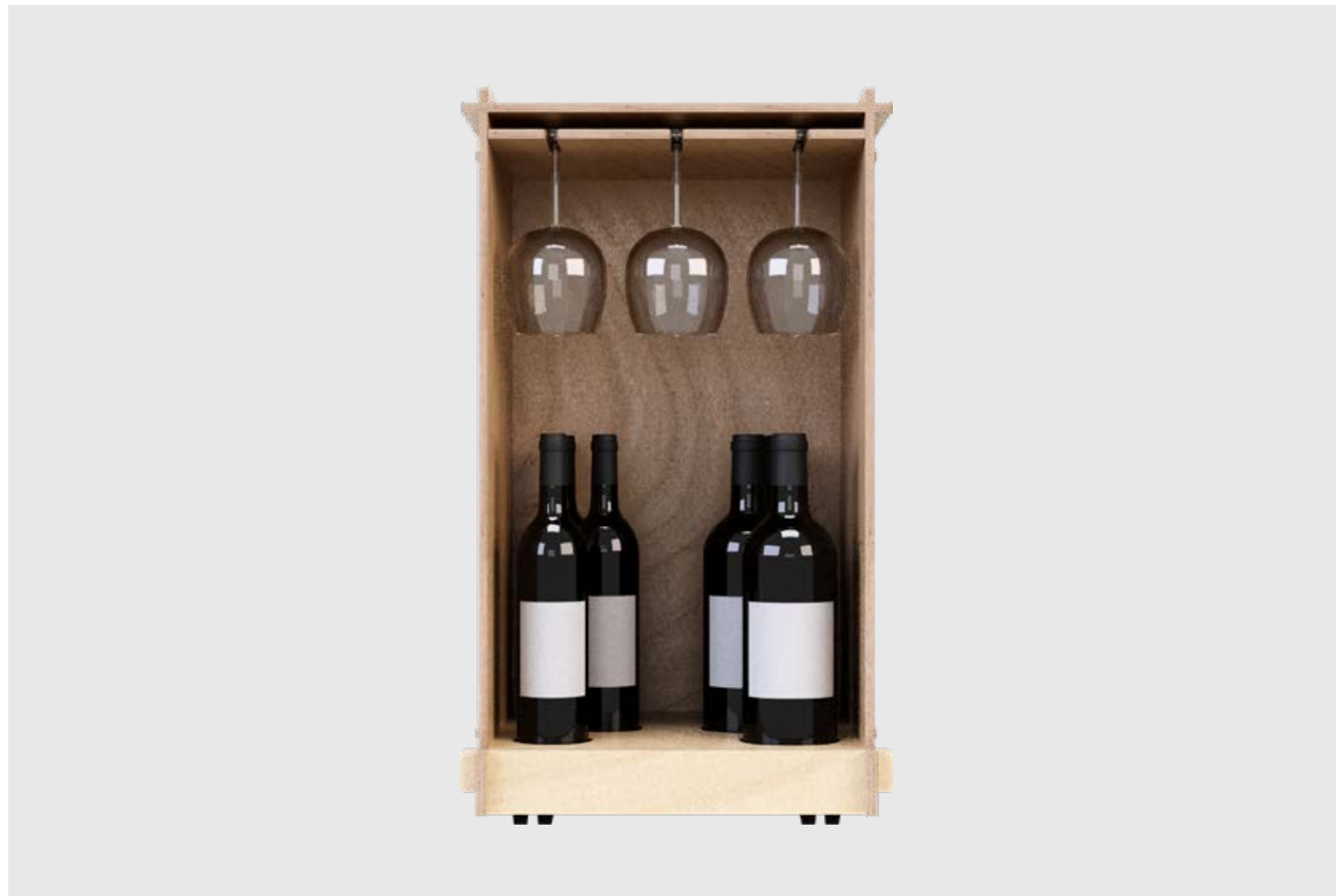

## Wine Cube

Designed to hold 6 bottles and 9 glasses, this versatile wine tasting cart is perfect for creating an elegant display.

Its compact size allows it to be conveniently placed on a table or countertop, making it ideal for retail spaces with limited room.

With a quick and easy interlocking assembly, it requires minimal effort to set up. The lightweight wooden structure and smooth rolling wheels make it easy to transport and position wherever needed.

**Material:**

- Eucalyptus 9 mm
- 4 wheels

**Weight:**

7 kg

**Package (WxDxH):**

80x50x5 cm

**Customization:**

- Painting
- Graphic printing

So **light**  
So **adjustable**  
So **sustainable**

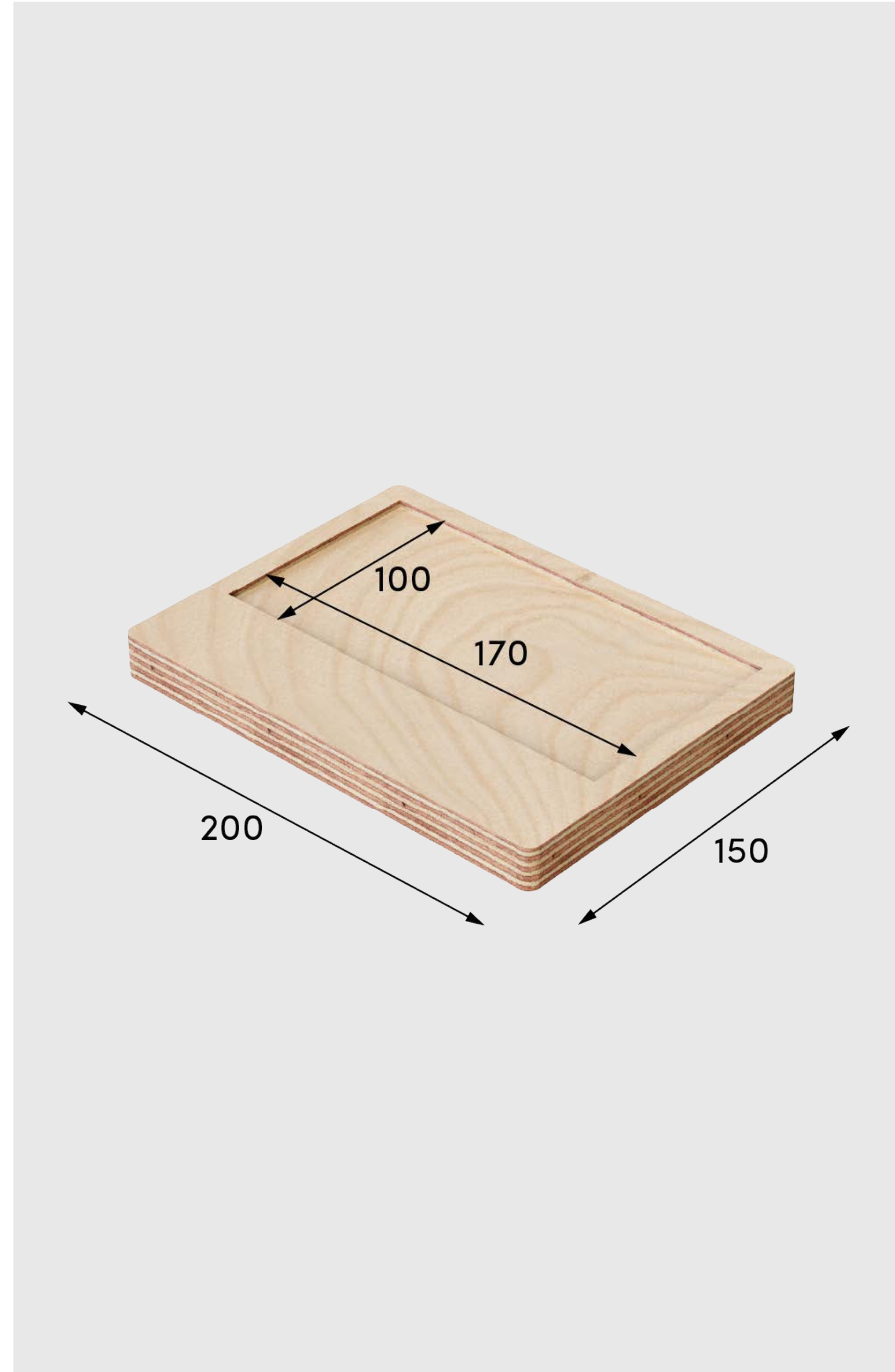

## Argo

Characterized by a compact and minimal design, this display system is an excellent choice for showcasing essential oils, fragrances, and other personal care products. Its versatile design also makes it ideal for displaying cosmetics, creams, perfumes, and skincare items.

Crafted from FSC-certified wood sourced from sustainable forests, it provides a stylish and eco-friendly way to present your brand. The quick interlocking assembly ensures hassle-free setup, saving you time and effort. Plus, its lightweight wooden structure makes it easy to move and position wherever you need it.

**Material:**

- Eucalyptus 18 mm

**Weight:**

0,2 kg

**Package (WxDxH):**

30x20x4 cm

**Customization:**

- Painting
- Graphic printing

So **light**  
So **adjustable**  
So **sustainable**

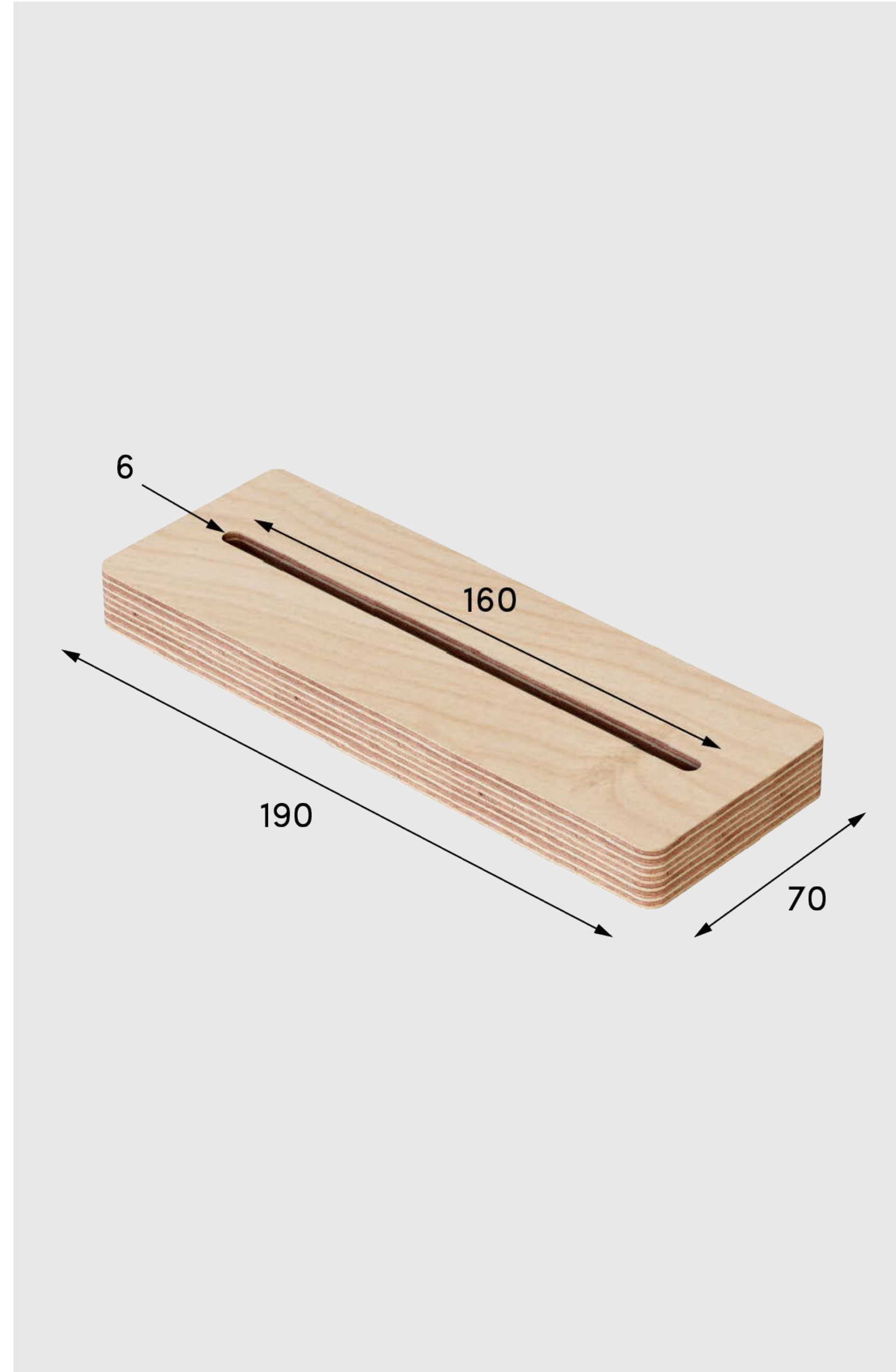

## Kero

Table Tray for Menu Display

Crafted from FSC-certified wood sourced from sustainable forests, this table tray provides an eco-friendly and stylish way to display menus and price lists while promoting your brand responsibly. Perfect for restaurants, cafes, and events, it adds a touch of natural elegance to your tabletop presentation.

**Material:**

- Eucalyptus 18 mm

**Weight:**

0,2 kg

**Package (WxDxH):**

30x10x4 cm

**Customization:**

- Painting
- Graphic printing

So **light**  
So **adjustable**  
So **sustainable**

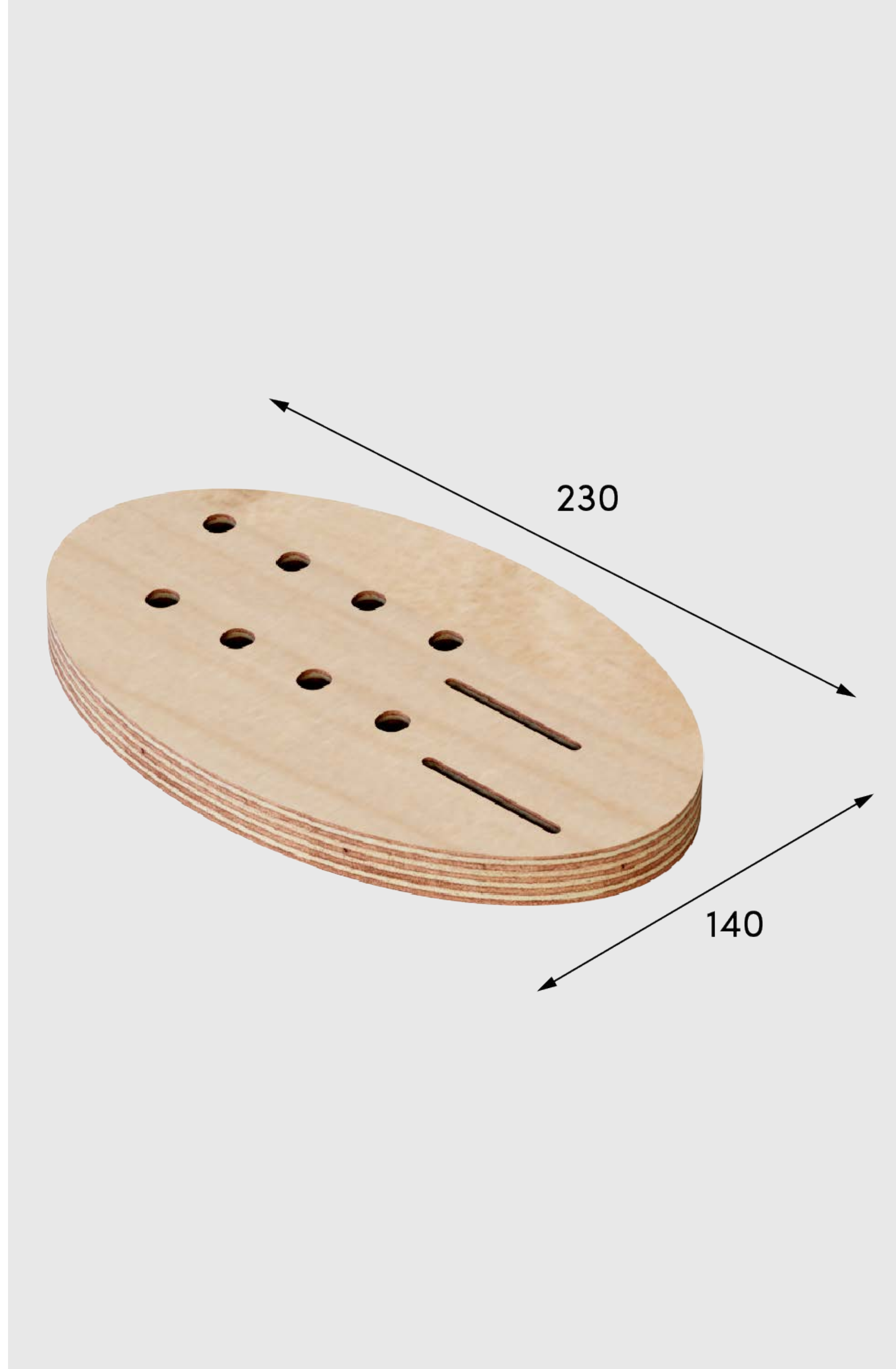

# Lumi

## Tabletop Pencil Holder Tray

Crafted from FSC-certified wood sourced from sustainable forests, this pencil holder tray provides an eco-friendly and stylish way to organize and display writing utensils while promoting your brand responsibly. Its lightweight wooden construction ensures easy transport and flexible placement, making it a practical addition to desks, counters, or event spaces.

**Material:**

- Eucalyptus 18 mm

**Weight:**

0,3 kg

**Package (WxDxH):**

30x20x4 cm

**Customization:**

- Painting
- Graphic printing

So **light**  
So **adjustable**  
So **sustainable**



## Yalo

With its minimal footprint and innovative design, this display system is perfect for showcasing essential oils and fragrances. It's also a great fit for displaying cosmetics, creams, perfumes, and other personal care products.

Crafted from FSC-certified wood sourced from sustainable forests, this display provides an eco-friendly and responsible way to promote your brand. The easy interlocking assembly allows you a hassle-free quick setup, saving you valuable time.

Plus, its lightweight wooden construction makes it effortless to transport and position wherever you need it.

**Material:**

- Eucalyptus 18 mm

**Weight:**

0,4 kg

**Package (WxDxH):**

30x20x4 cm

**Customization:**

- Painting
- Graphic printing

So **light**  
So **adjustable**  
So **sustainable**



# Albus

Sturdy Floor Display with Full Back Panel – Ideal for Glass Bottles  
 Designed for strength and stability, this floor display is perfect for holding glass bottles while taking up minimal space. Its durable structure ensures reliable support for heavy loads, making it a practical choice for retail spaces and events. Crafted from FSC-certified wood sourced from sustainable forests, this display offers an eco-friendly and responsible way to showcase and promote your brand. With a quick snap-fit assembly, it requires minimal effort to set up, saving you valuable time. Plus, its lightweight wooden construction makes it easy to transport and position wherever you need it.

**Material:**  
 - Eucalyptus 9 mm

**Weight:**  
 9 kg

**Package (WxDxH):**  
 160x45x6 cm

**Customization:**  
 - Painting  
 - Graphic printing

So **light**  
 So **adjustable**  
 So **sustainable**

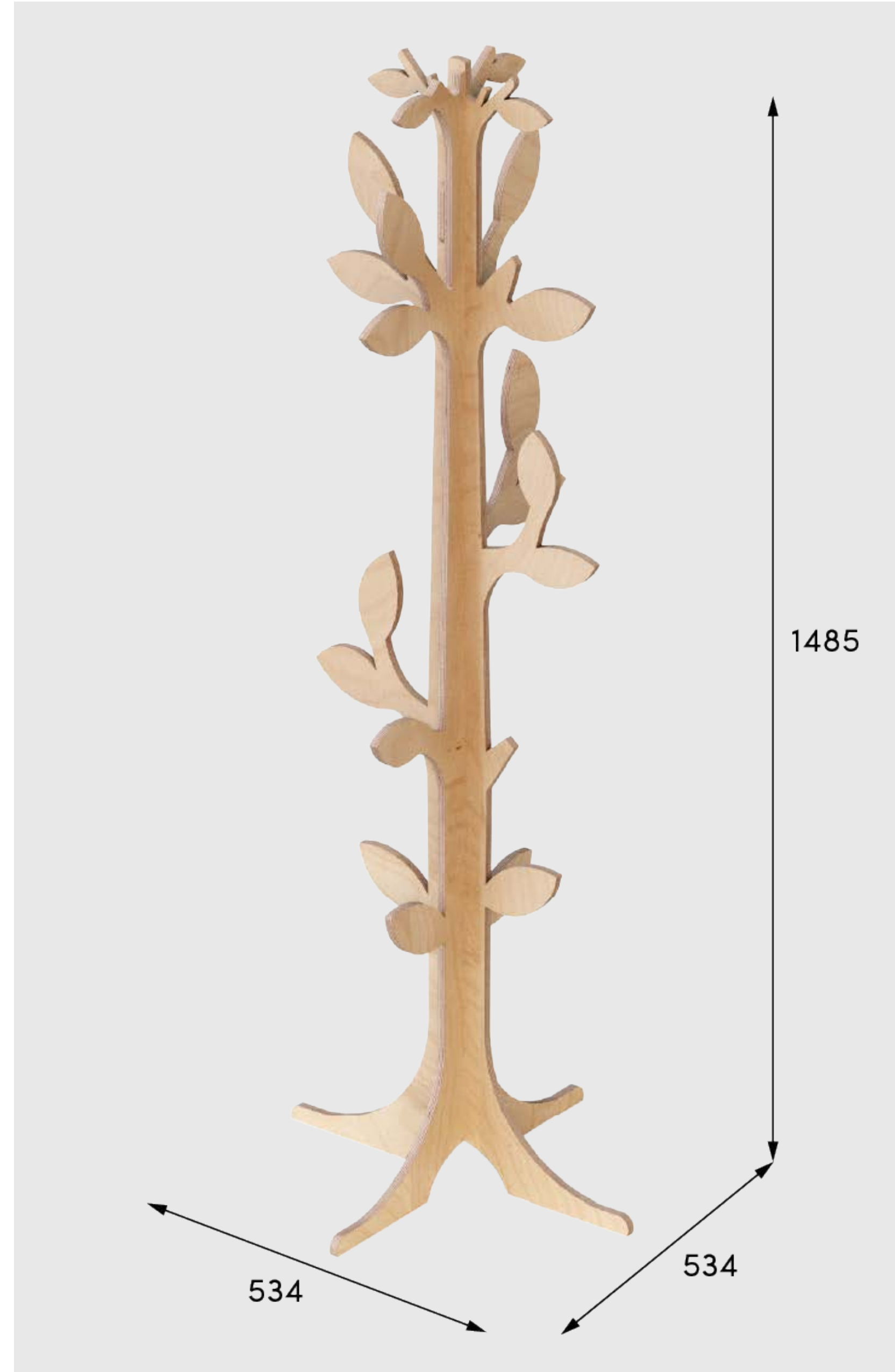

## Attakkino

Combining elegance with practicality, this interlocking coat rack offers a sleek, space-saving design that is perfect for both trade shows and home use.

Crafted from FSC-certified wood sourced from sustainable forests, it's an eco-friendly choice that reflects your commitment to sustainability.

The easy interlocking assembly allows you a hassle-free quick setup, saving you valuable time.

**Material:**

- Eucalyptus 12 mm

**Weight:**

3 kg

**Package (WxDxH):**

146x54x5 cm

**Customization:**

- Painting
- Graphic printing

So **light**  
So **adjustable**  
So **sustainable**

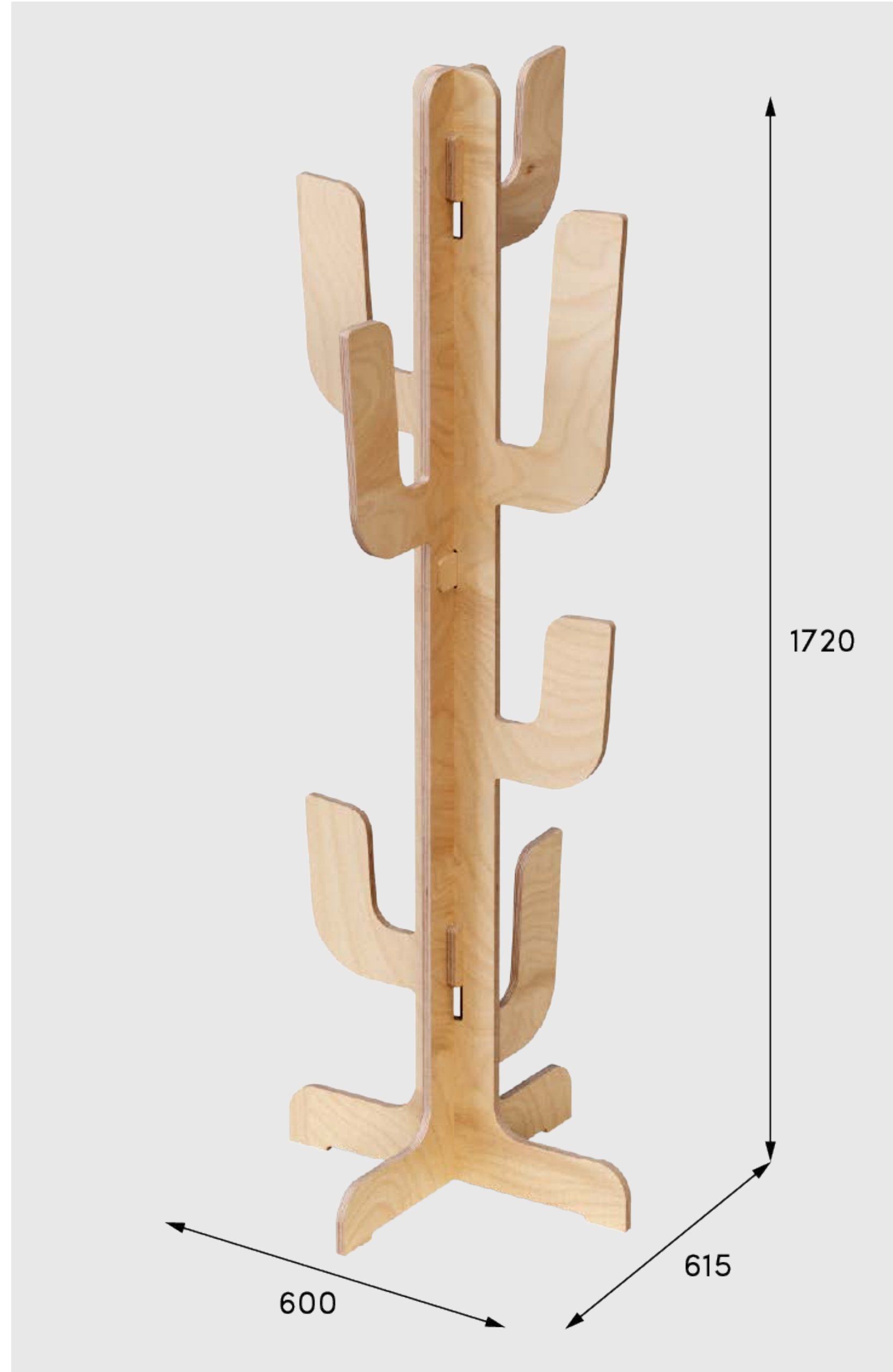
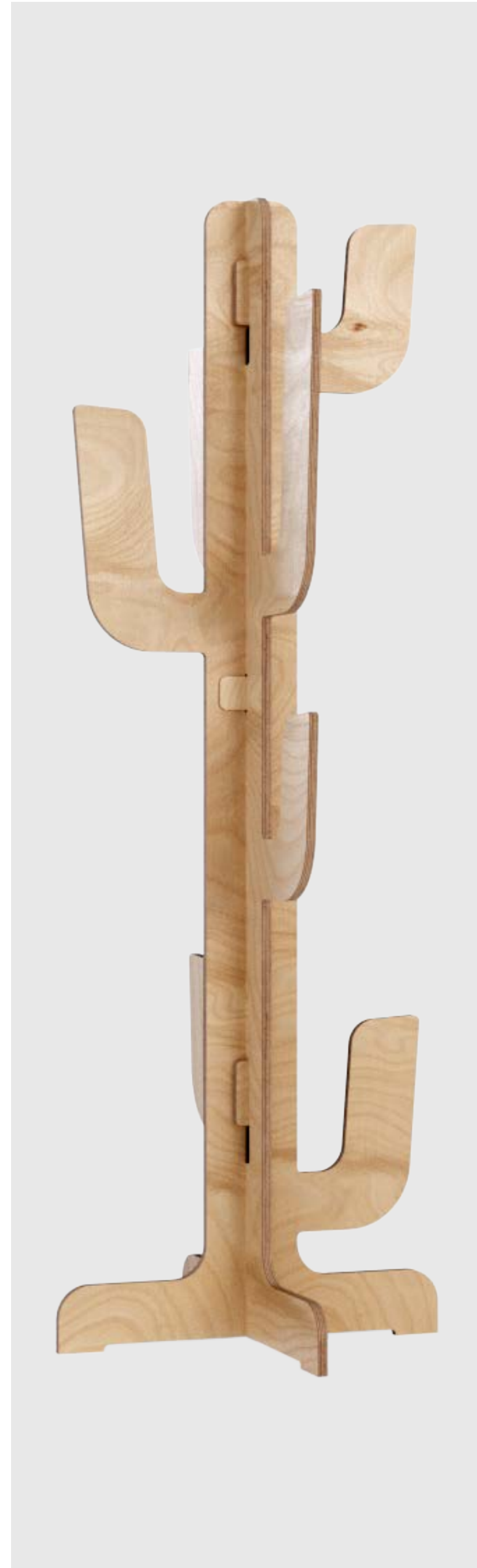

## Tacos

Interlocking Coat Rack- Stylish and Functional for Trade Shows and Home Use

Combining sleek design with a minimal footprint, this interlocking coat rack is a smart, space-saving solution for both trade show exhibits and everyday home use.

Its clean lines and natural wood finish add a touch of elegance to any environment.

Crafted from FSC-certified wood sourced from sustainable forests, it's an eco-friendly choice that supports environmentally responsible production.

**Material:**

- Eucalyptus 15 mm

**Weight:**

9 kg

**Package (WxDxH):**

200x74x5 cm

**Customization:**

- Painting
- Graphic printing

So **light**  
So **adjustable**  
So **sustainable**



## Berry

With its functional bar design, this display system is ideal for showcasing clothing products and accessories like scarves, ties, shawls, and belts. It's also a great choice for displaying gift wrapping rolls, ribbons, or even hanging plush toys.

Crafted from FSC-certified wood sourced from sustainable forests, this display offers an eco-friendly and responsible way to promote your brand. The quick installation via an interlocking system requires minimal effort, saving you valuable time.

Additionally, the lightweight wooden structure makes it simple to transport and provides flexible placement options to suit your needs.

**Material:**

- Eucalyptus 15 mm

**Weight:**

9 kg

**Package (WxDxH):**

160x50x6 cm

**Customization:**

- Painting
- Graphic printing

So **light**  
So **adjustable**  
So **sustainable**

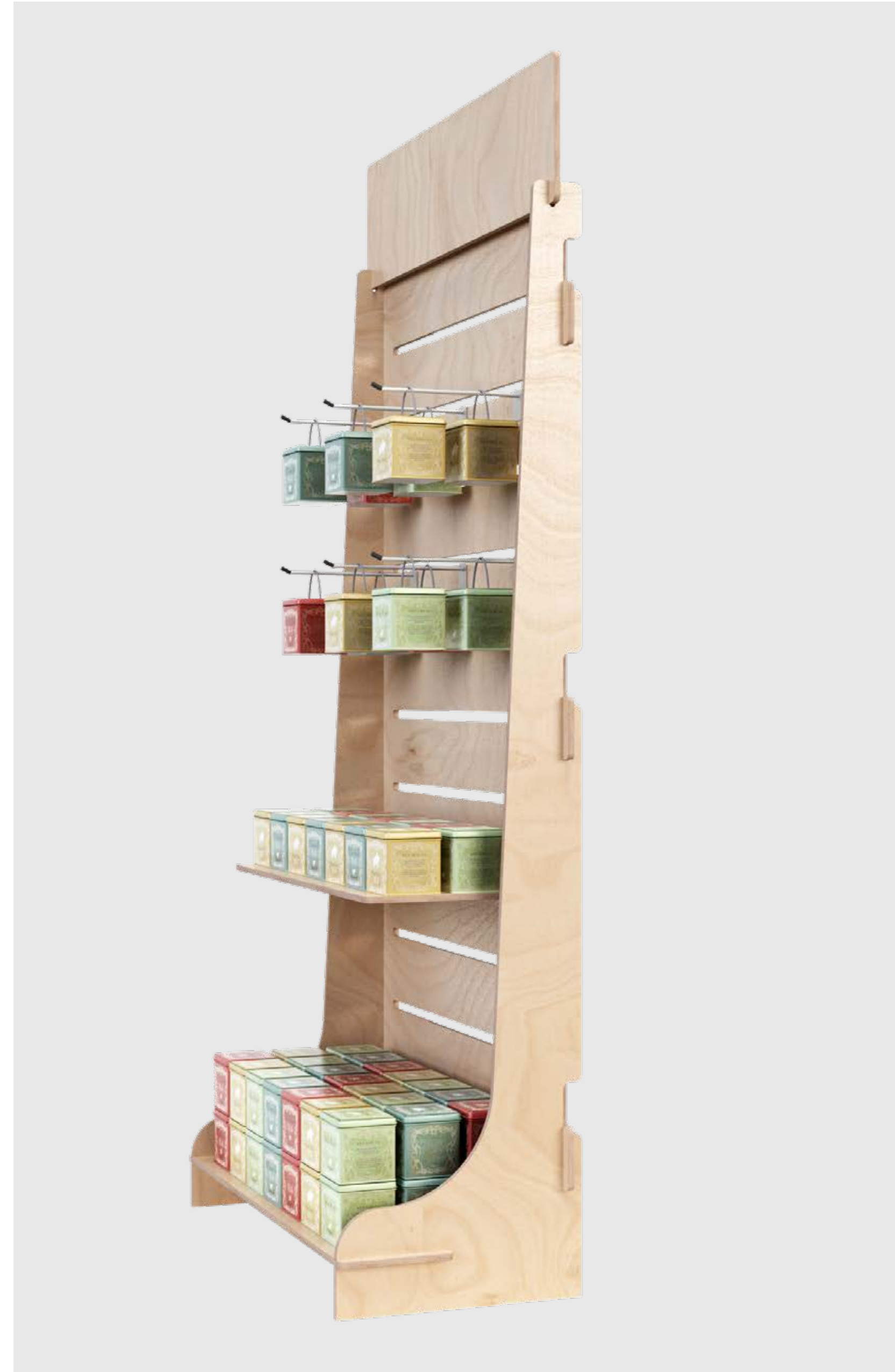
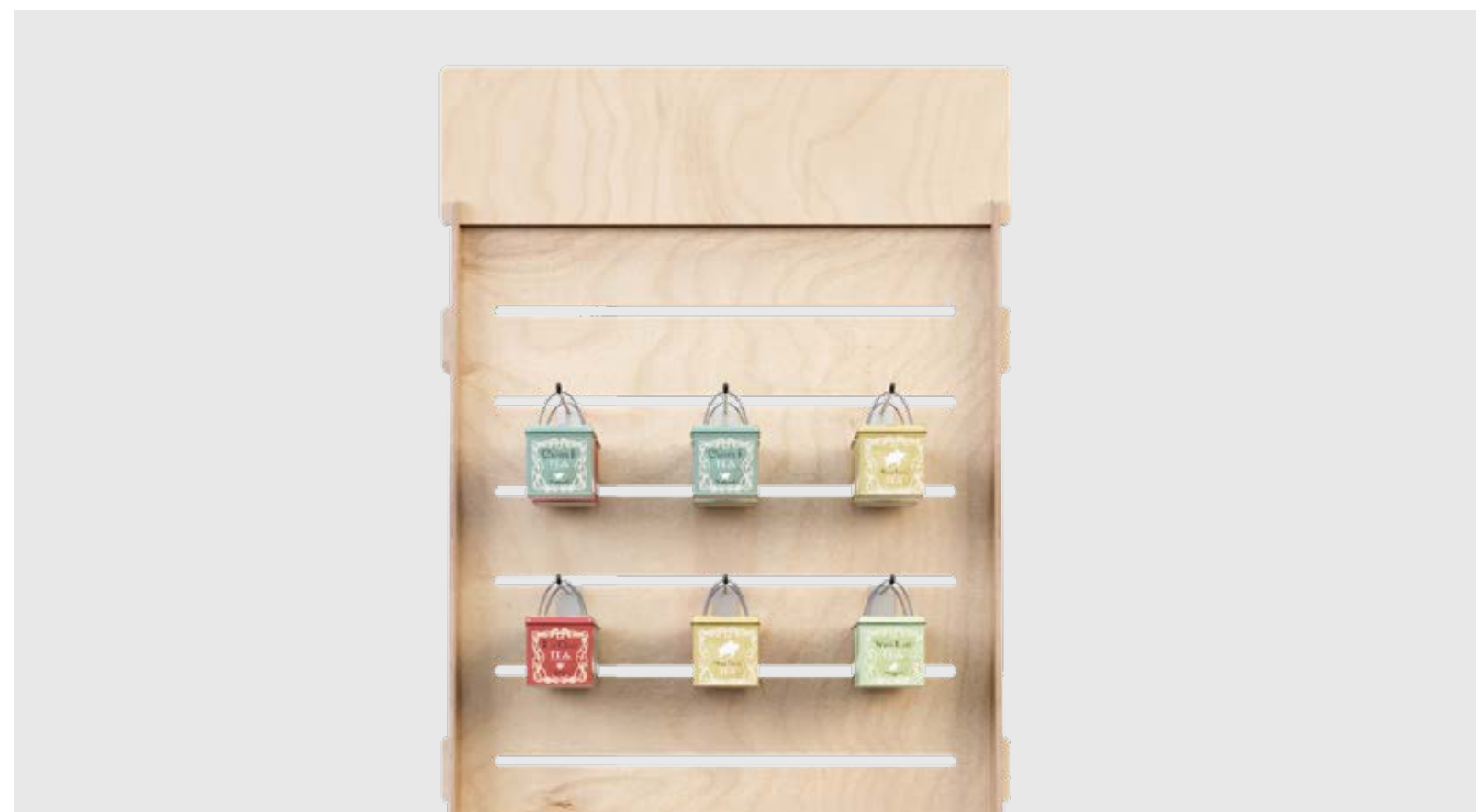
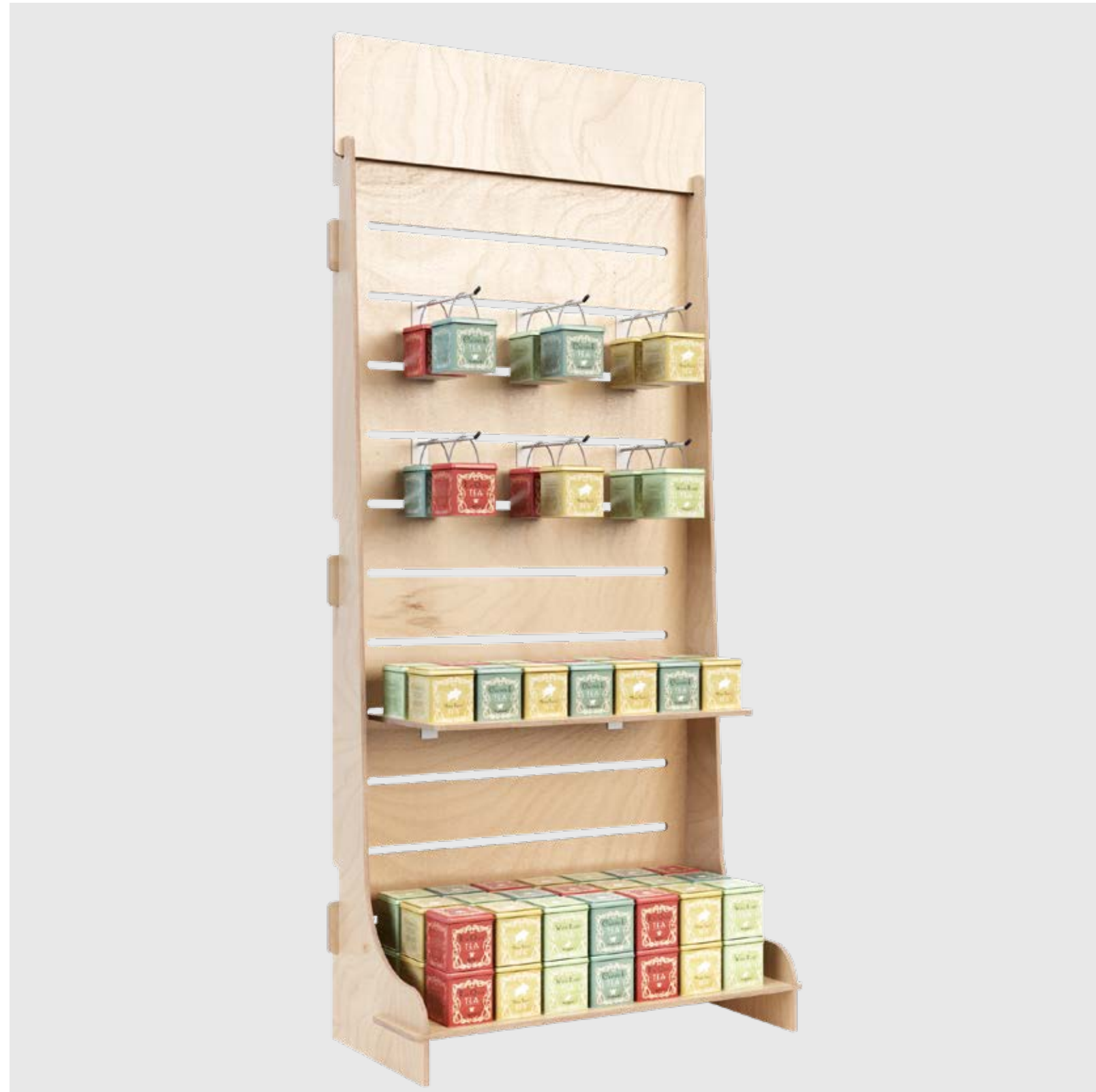

## Blister

This adaptable floor display can be equipped with iron hooks for hanging products or wooden shelves for showcasing items, making it perfect for a variety of retail settings.

Crafted from FSC-certified wood sourced from sustainable forests, it offers an eco-friendly and responsible way to promote your brand.

The easy interlocking assembly allows you a hassle-free quick setup, saving you valuable time.

Plus, its lightweight wooden construction makes it effortless to transport and position wherever you need it.

So **light**  
So **adjustable**  
So **sustainable**

**BLISTER Quattro**



**BLISTER Sette**



**BLISTER Nove**



**Material:**

- Eucalyptus 9 mm

**Blister Quattro:**

- 8 iron hooks da 20cm

**Blister Sette:**

- 6 iron hooks da 20cm
- 1 shelf

**Blister Nove:**

- 4 iron hooks da 20cm
- 4 shelves

**Weight:**

- Blister Quattro: 7 kg
- Blister Sette: 11 kg
- Blister Nove: 12 kg

**Package (WxDxH):**

- Blister Quattro: 160x73x6 cm
- Blister Sette: 160x73x6 cm
- Blister Nove: 160x100x6 cm

**Customization:**

- Painting
- Graphic printing

So **light**  
So **adjustable**  
So **sustainable**

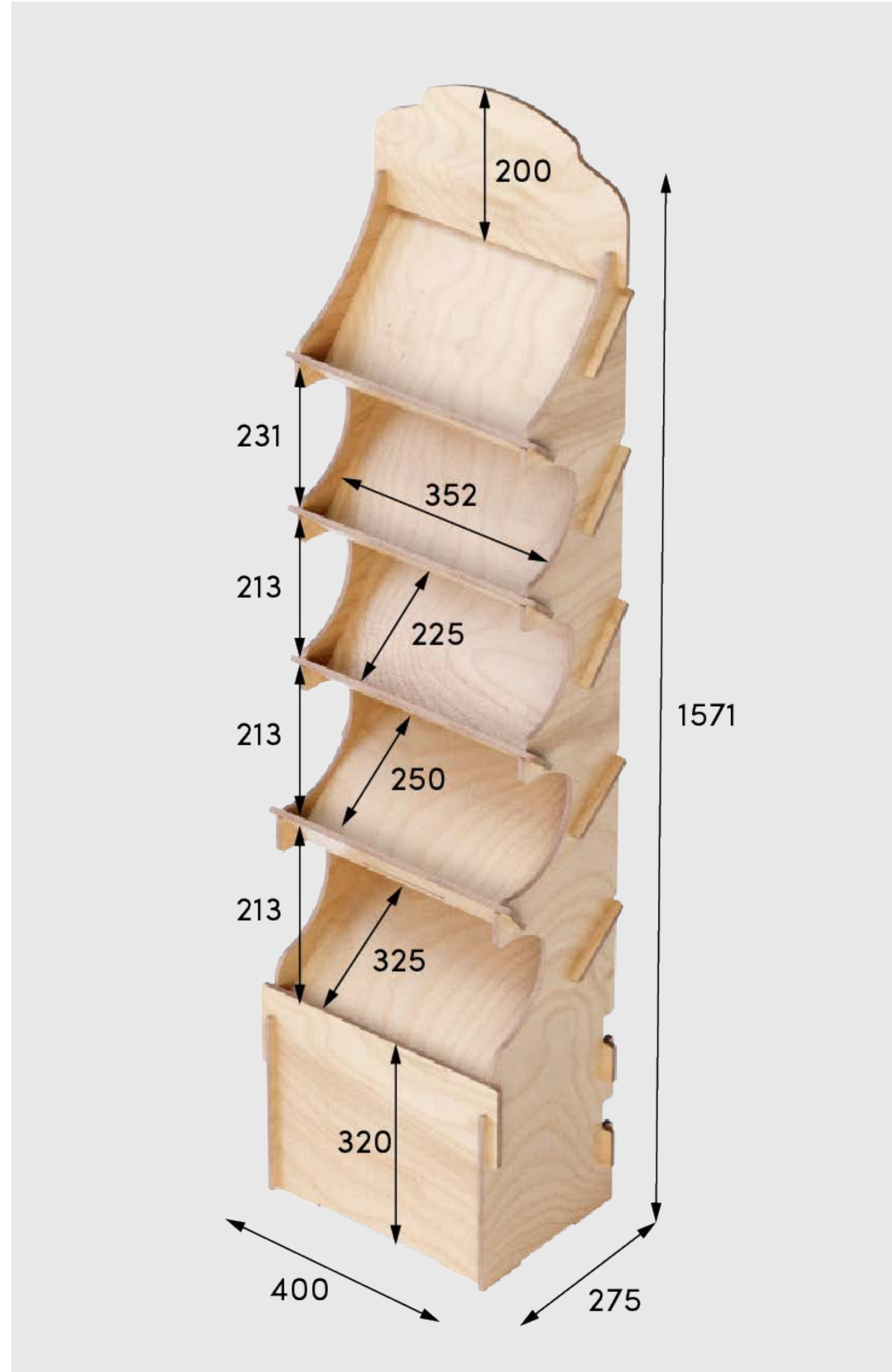
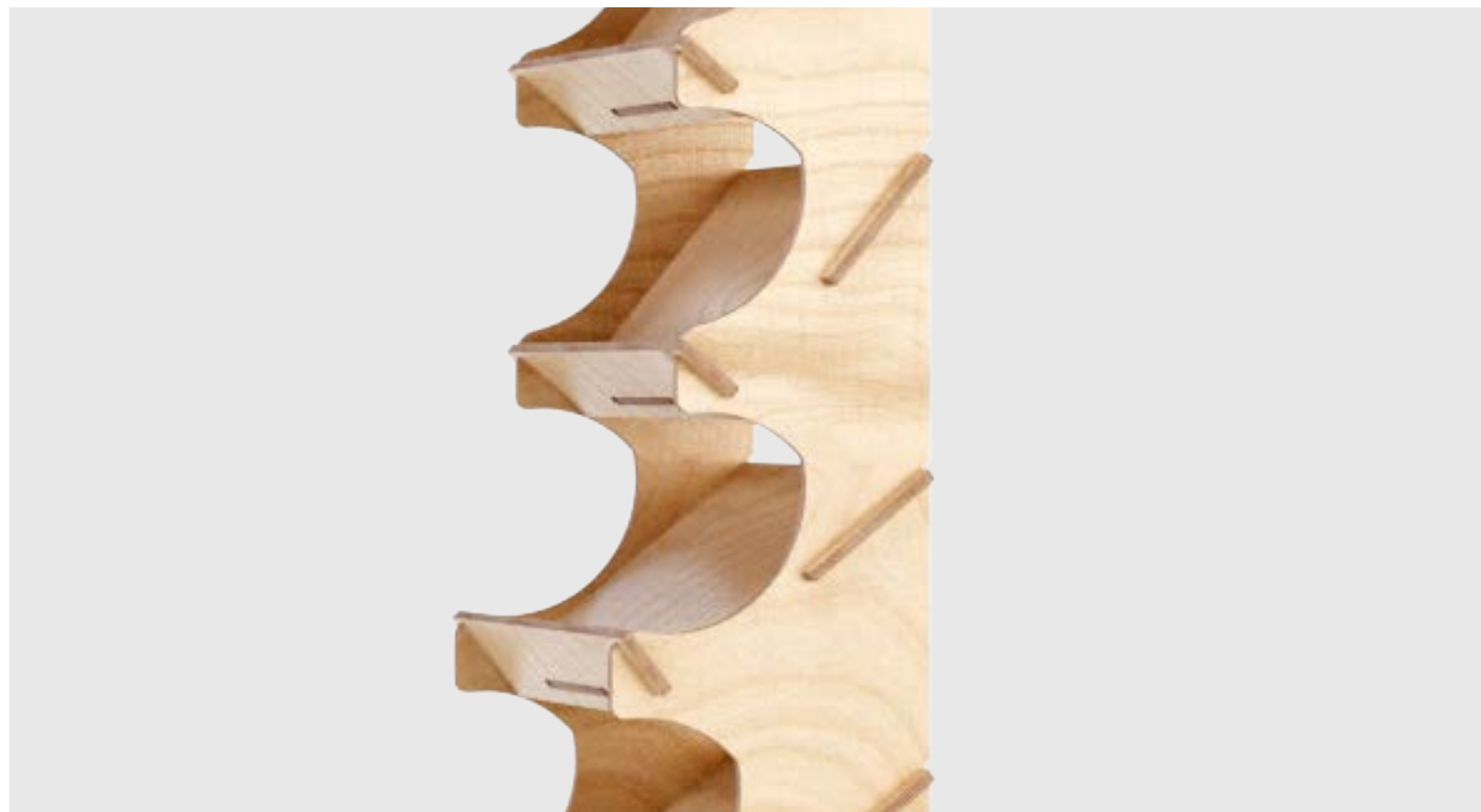
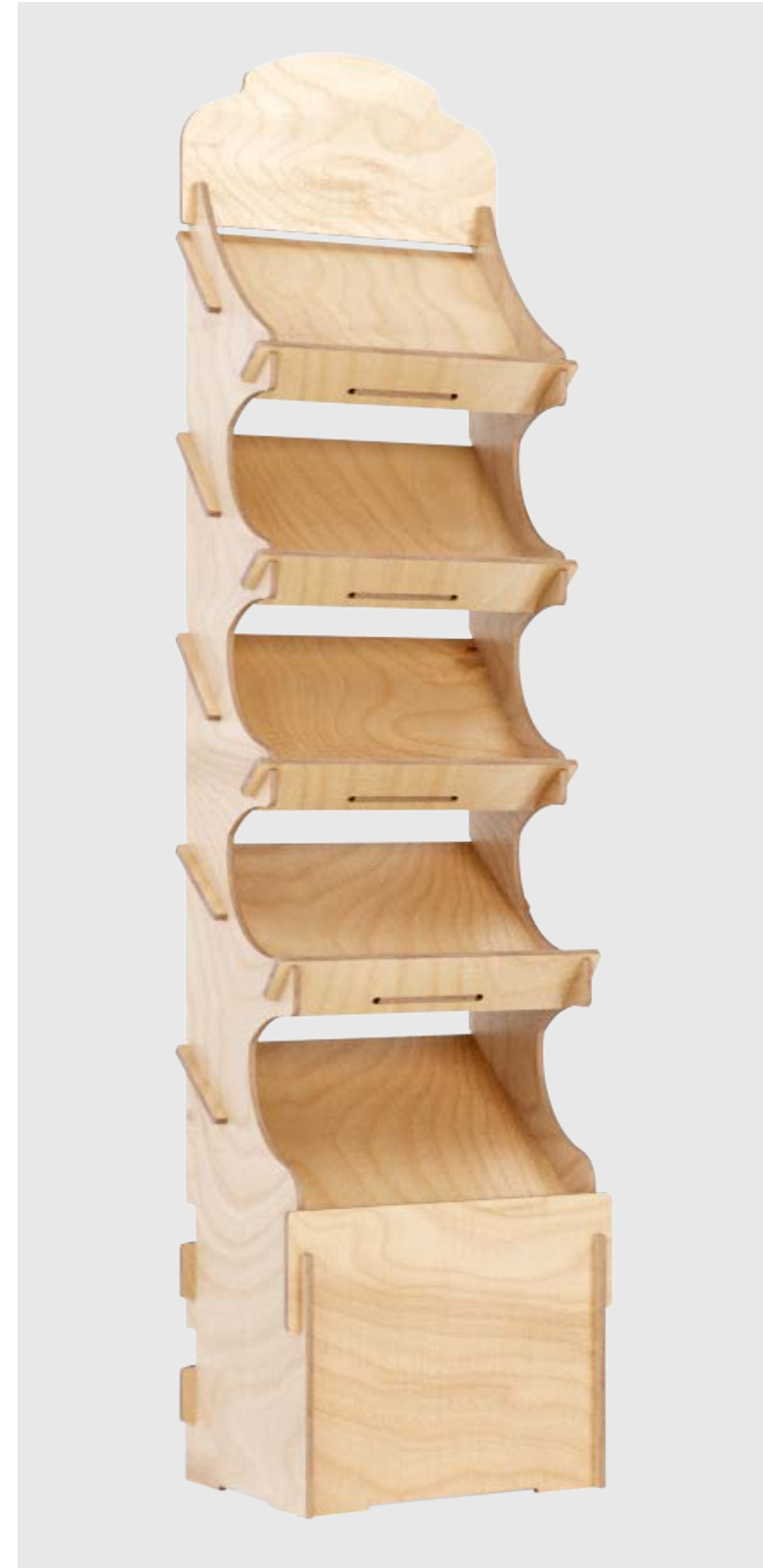
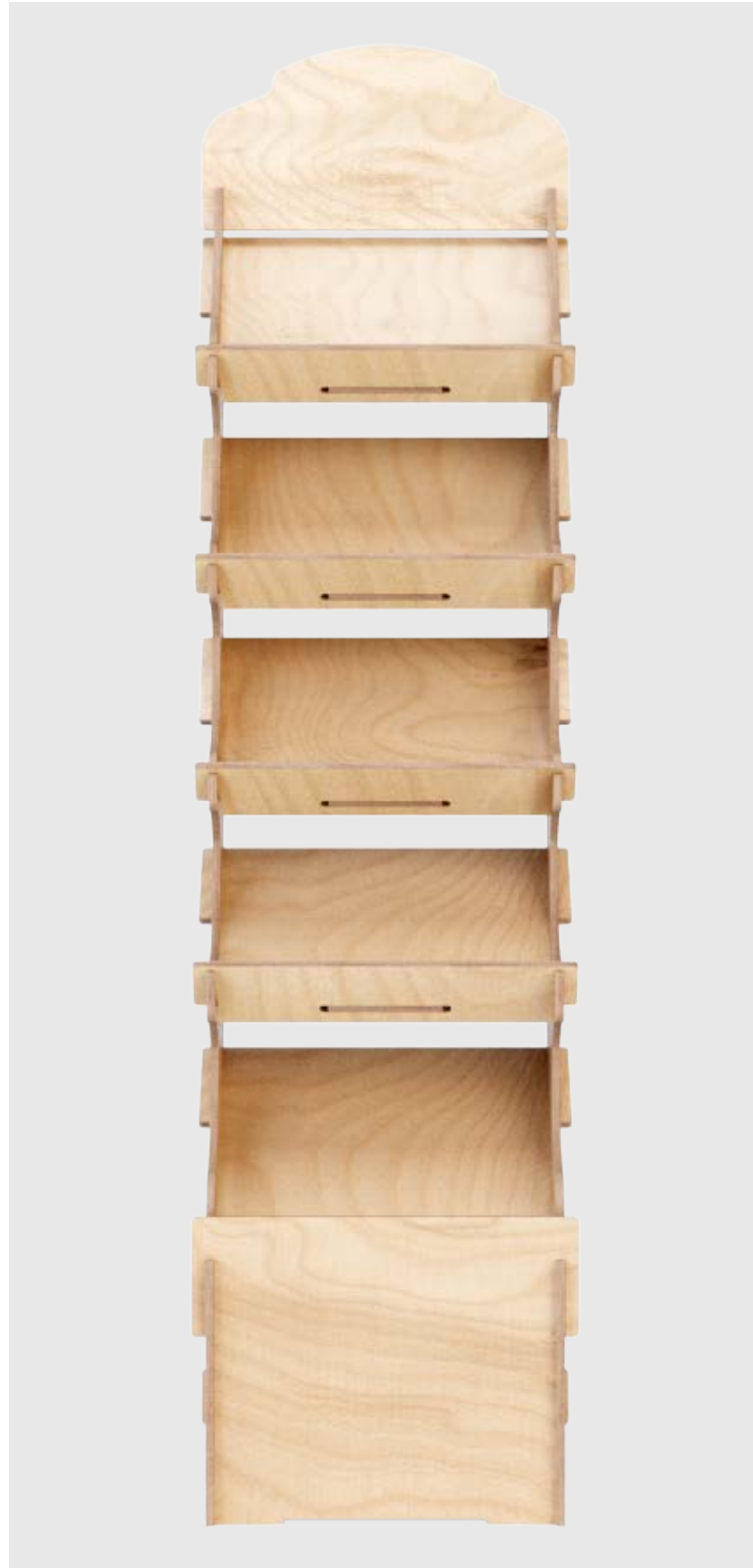

## Celsius

Floor Display with Forward-Inclined Shelves

Designed with forward-inclined shelves for optimal product visibility, this floor display is a stylish and practical solution for showcasing your items.

Crafted from FSC-certified wood sourced from sustainable forests, it provides an eco-friendly and efficient way to promote your brand. The easy interlocking assembly ensures quick and effortless setup, saving you valuable time.

Plus, its lightweight wooden structure makes it easy to move and position wherever you need it.

**Material:**

- Eucalyptus 9 mm

**Weight:**

7 kg

**Package (WxDxH):**

160x45x6 cm

**Customization:**

- Painting
- Graphic printing

So **light**  
So **adjustable**  
So **sustainable**

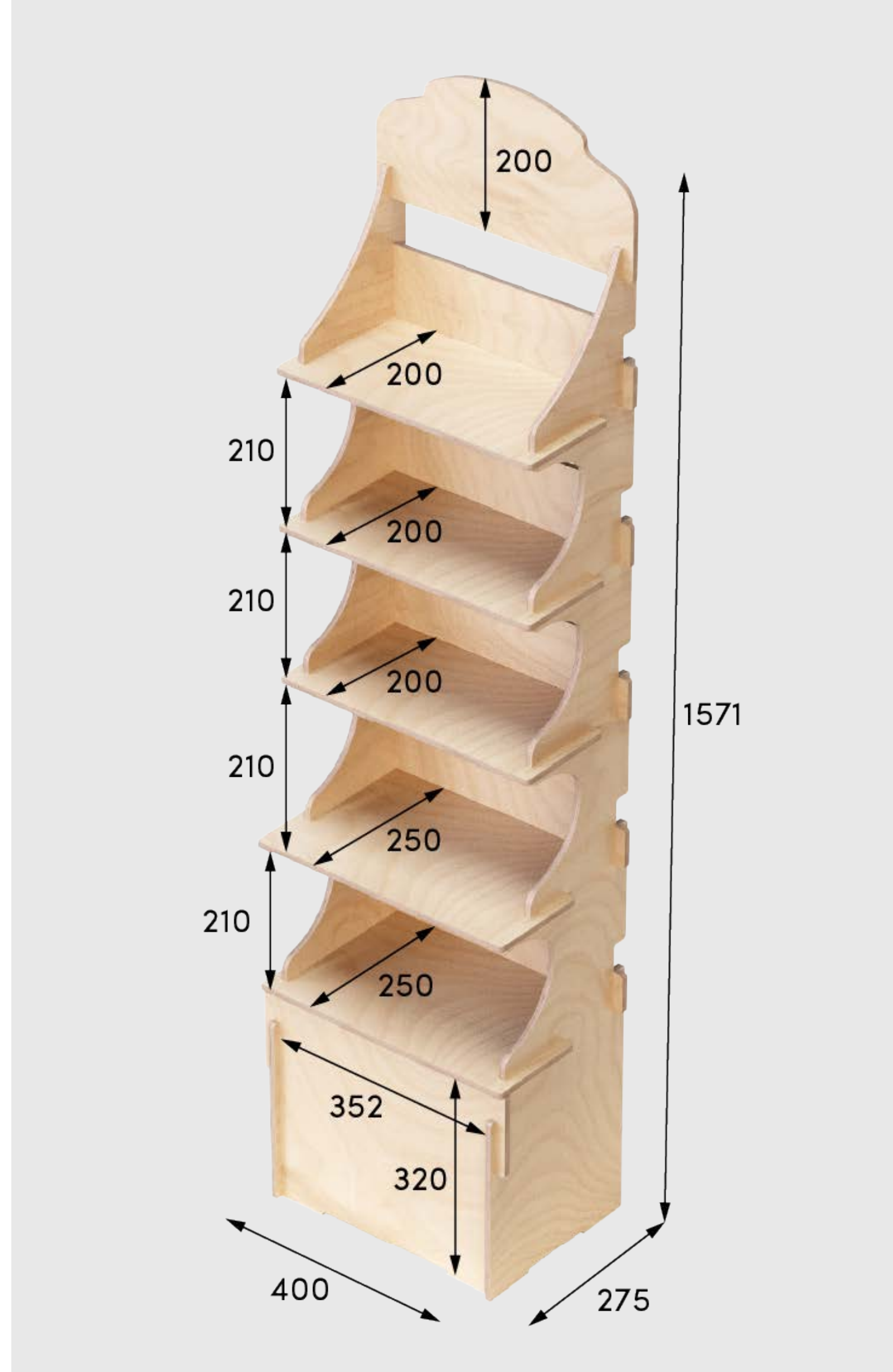
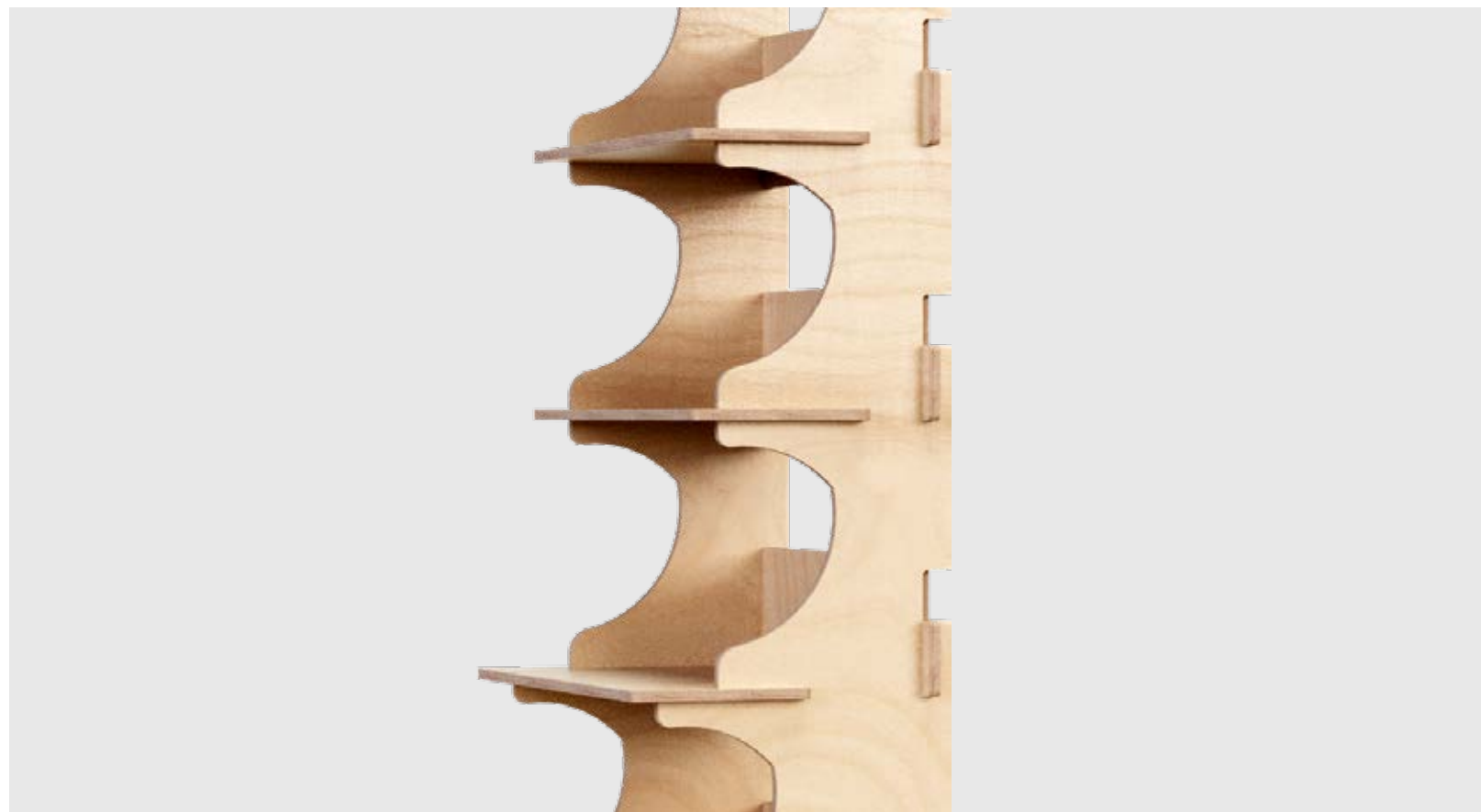
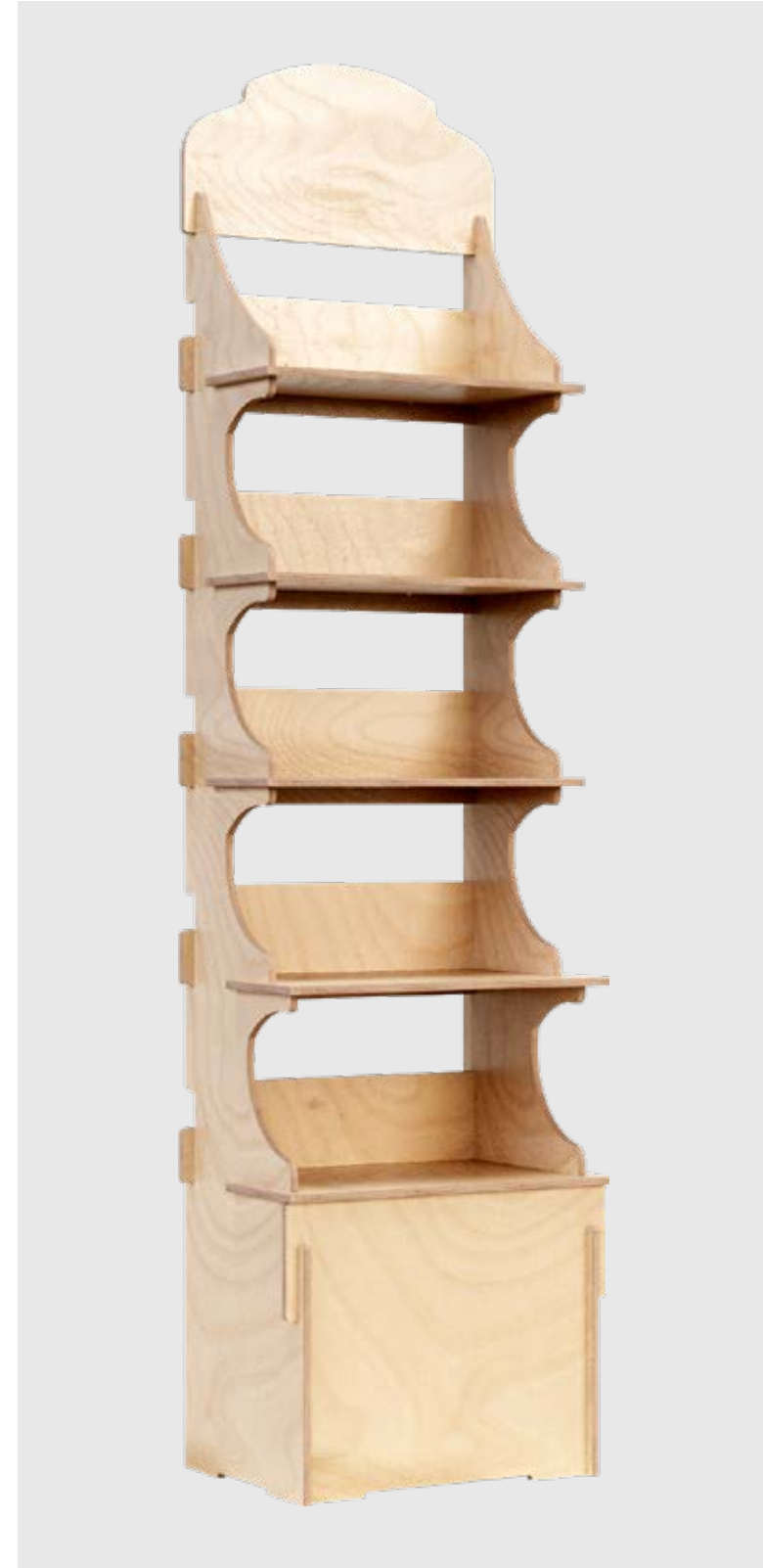
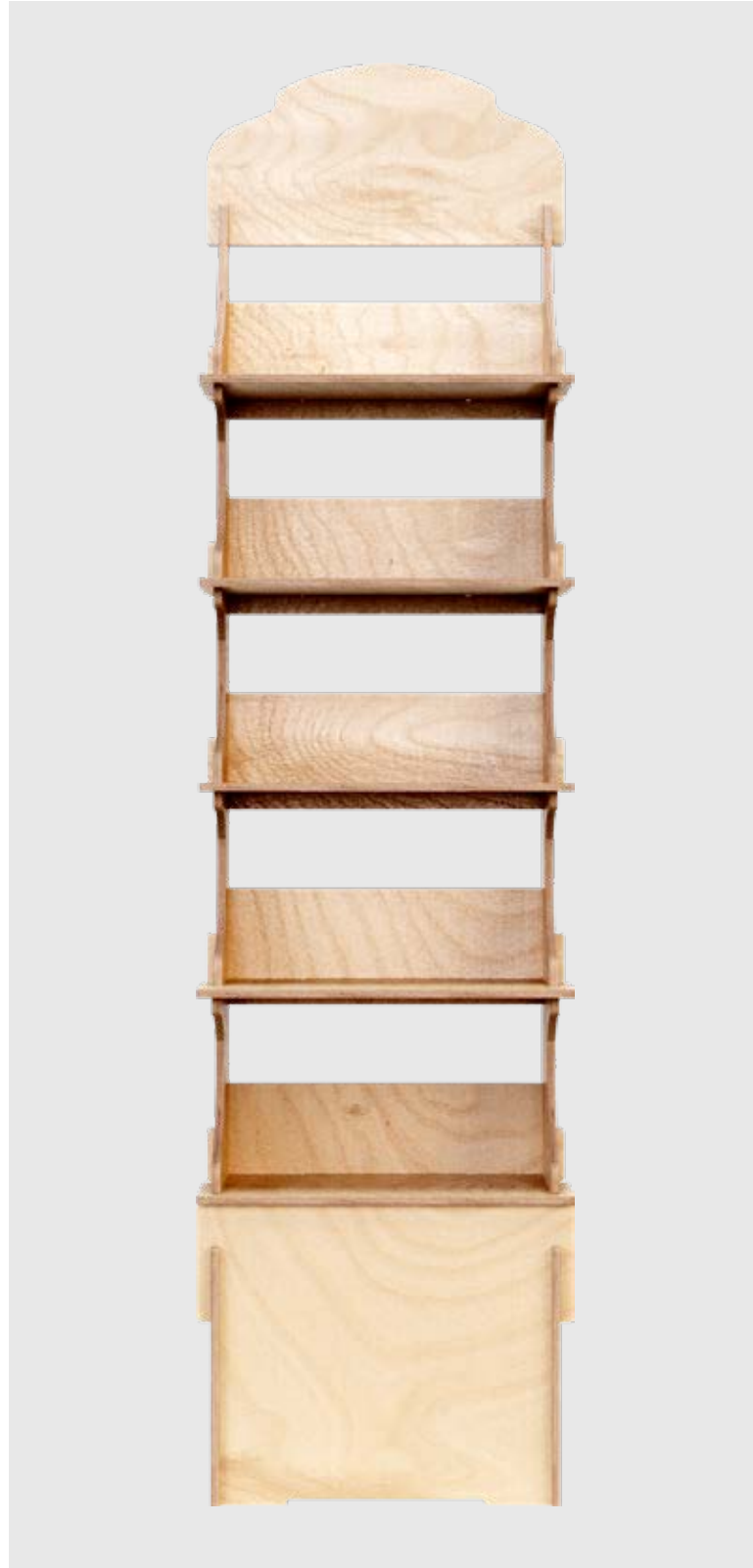

## Horizon

Maximize your display space with this five-shelf floor display, designed to offer ample product visibility while maintaining a small footprint. Perfect for retail point-of-sale environments, trade shows, or pop-up events, it provides an elegant and functional way to showcase your items. Crafted from FSC-certified wood sourced from sustainable forests, this display offers a full environmentally responsible solution for promoting your brand. The quick interlocking assembly requires minimal effort, saving you valuable time.

Additionally, the lightweight wooden structure makes it simple to transport and provides flexible placement options to suit your needs.

**Material:**

- Eucalyptus 9 mm

**Weight:**

7 kg

**Package (WxDxH):**

160x45x6 cm

**Customization:**

- Painting
- Graphic printing

So **light**  
So **adjustable**  
So **sustainable**



## Caos

This multi-purpose floor display offers a sleek and sturdy solution for showcasing your products in retail stores, trade shows, or pop-up events.

Its compact footprint ensures that it fits effortlessly into any space while maintaining excellent stability.

Made from FSC-certified wood sourced from sustainable forests, it's an eco-friendly and responsible choice for promoting your brand.

The quick interlocking assembly ensures hassle-free setup, saving you time and effort.

Plus, its lightweight wooden structure makes it easy to move and position wherever you need it.

So **light**  
So **adjustable**  
So **sustainable**

**CAOS 940.5**

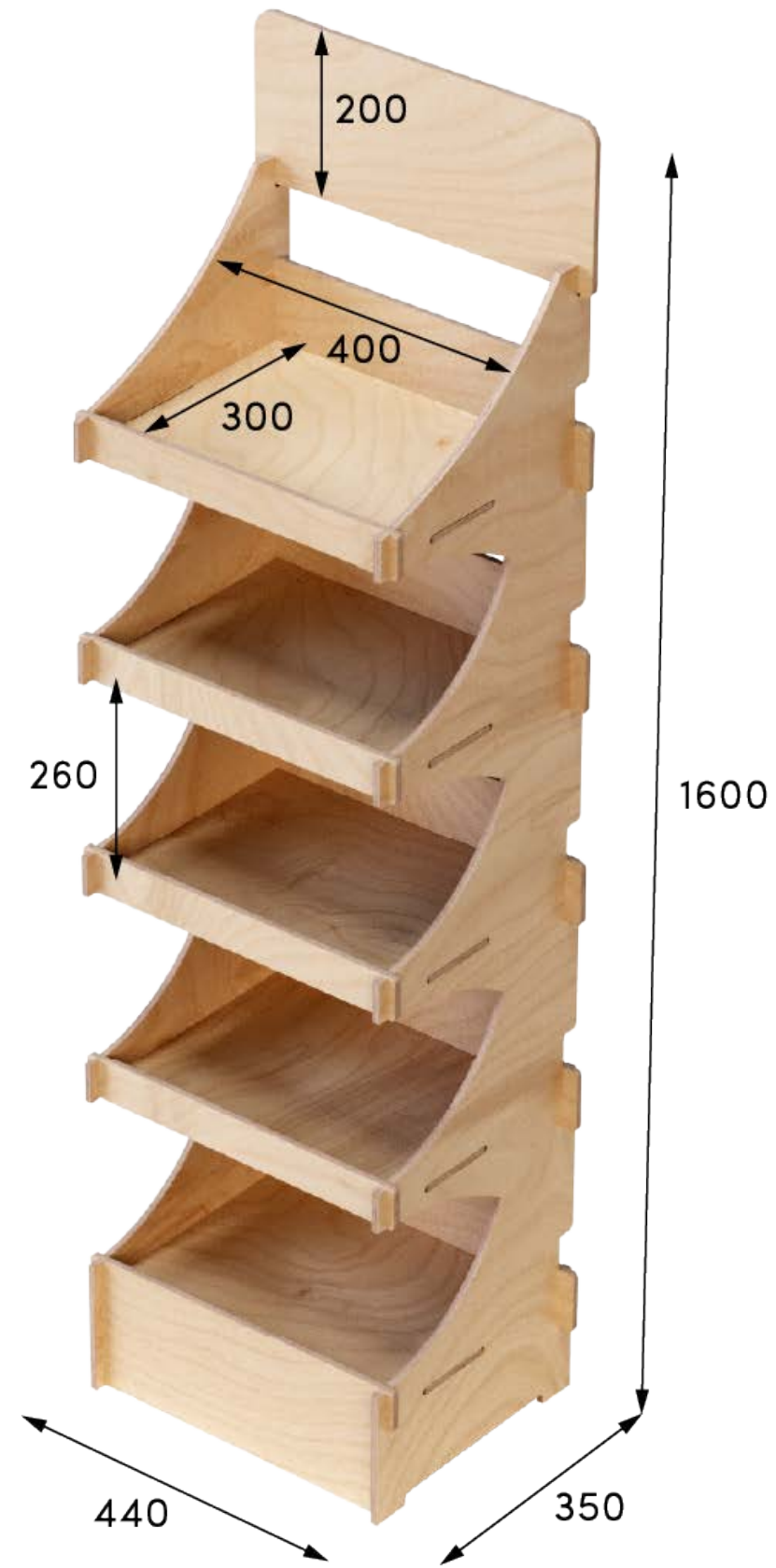

**CAOS 960.5**

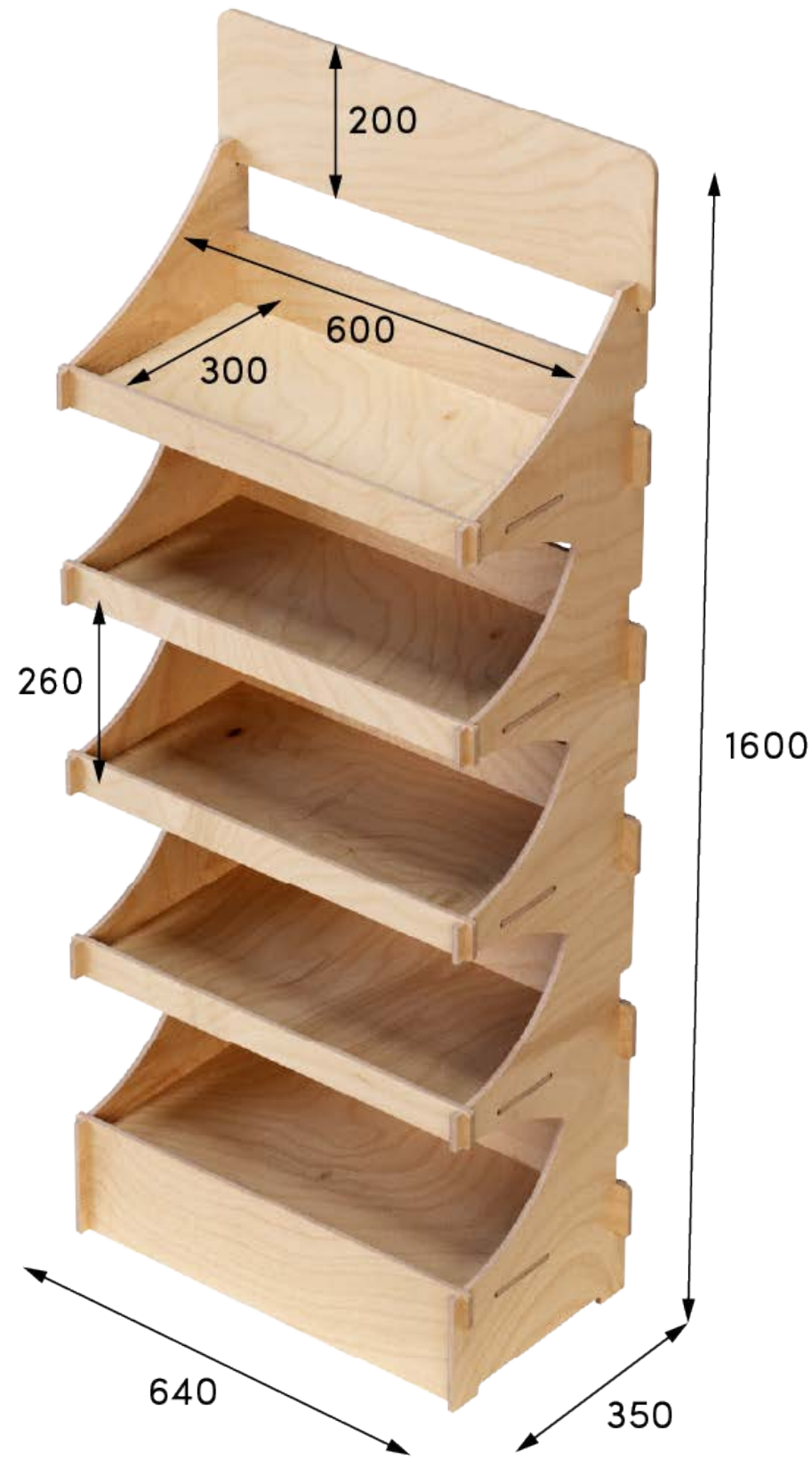

**CAOS 1240.4**



**CAOS 1260.4**

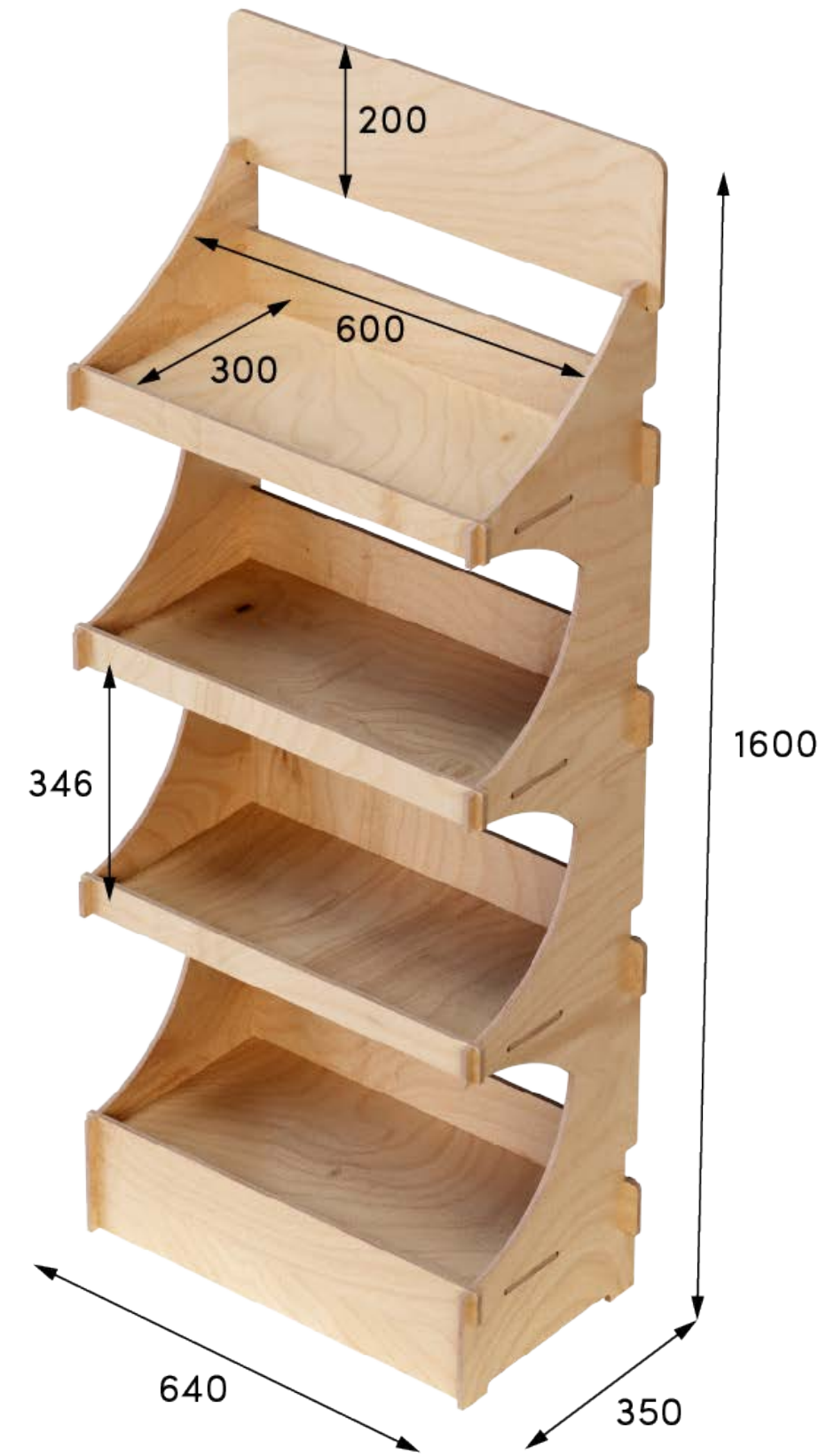

**Material:**

- Caos 940.5: Eucalyptus 9mm
- Caos 960.5: Eucalyptus 9mm
- Caos 1240.4: Eucalyptus 12mm
- Caos 1260.4: Eucalyptus 12mm

**Weight:**

- Caos 940.5: 13 kg
- Caos 960.5: 15 kg
- Caos 1240.4: 15 kg
- Caos 1260.4: 18 kg

**Package (WxDxH):**

- Caos 940.5: 160x45x6
- Caos 960.5: 160x45x6
- Caos 1240.4: 160x45x6
- Caos 1260.4: 160x45x6

**Customization:**

- Painting
- Graphic printing

So **light**  
So **adjustable**  
So **sustainable**



## Verso

### Interlocking Wall-Mounted Coat Rack

Featuring a sleek, minimalist design, this wall-mounted coat rack seamlessly complements any environment. It provides an organized and stylish solution for hanging coats, bags, and accessories while adding a modern touch to your space.

Crafted using an interlocking technique from FSC-certified wood sourced from sustainable forests, it's an eco-friendly choice that reflects your commitment to sustainability. The assembly requires minimal effort, saving you valuable time. Plus, its lightweight wooden construction makes it easy to transport and position wherever you need it.

**Material:**

- Eucalyptus 9 mm

**Weight:**

15 kg

**Package (WxDxH):**

120x34x4 cm

**Customization:**

- Painting
- Graphic printing

So **light**  
So **adjustable**  
So **sustainable**

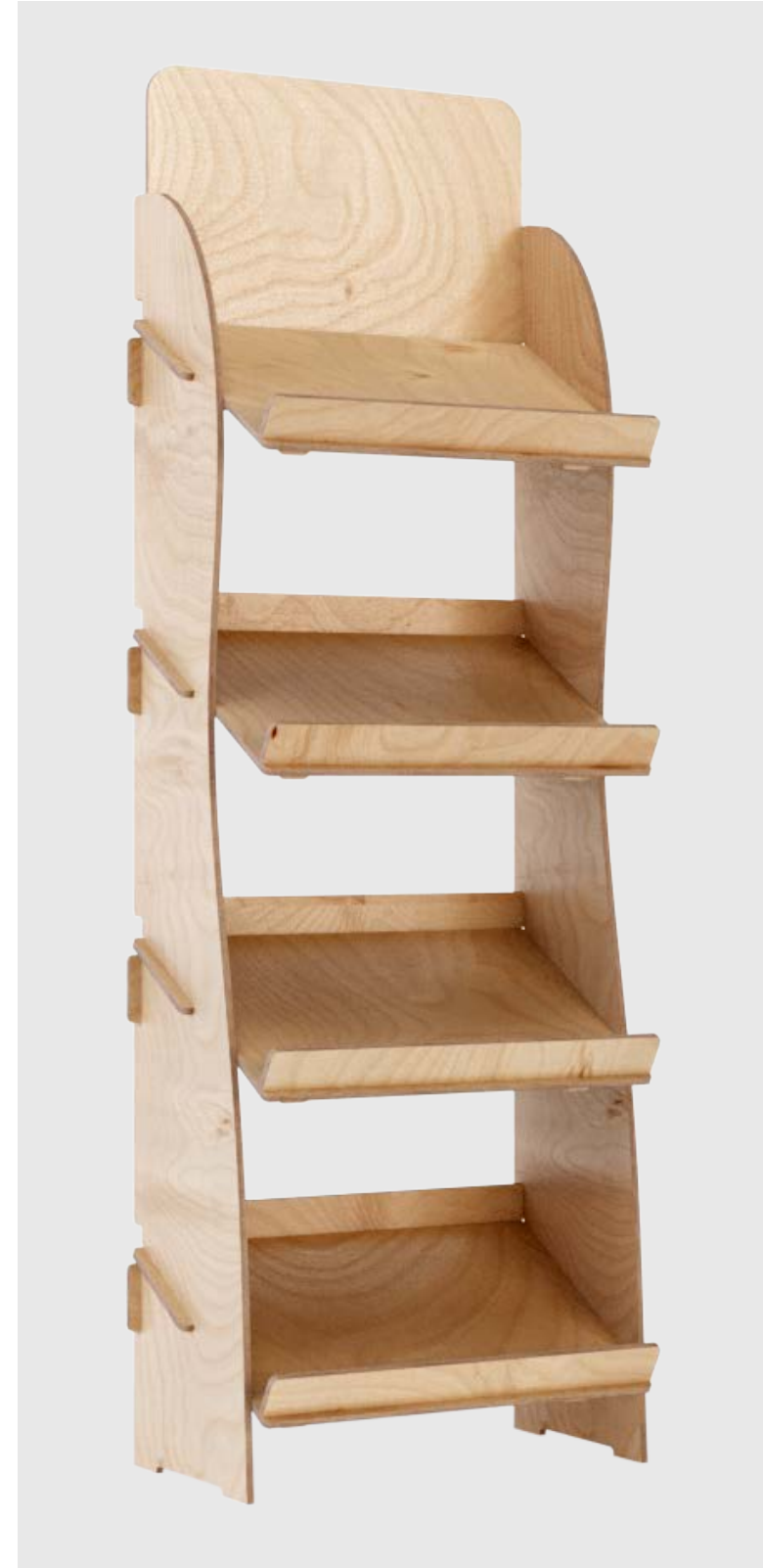
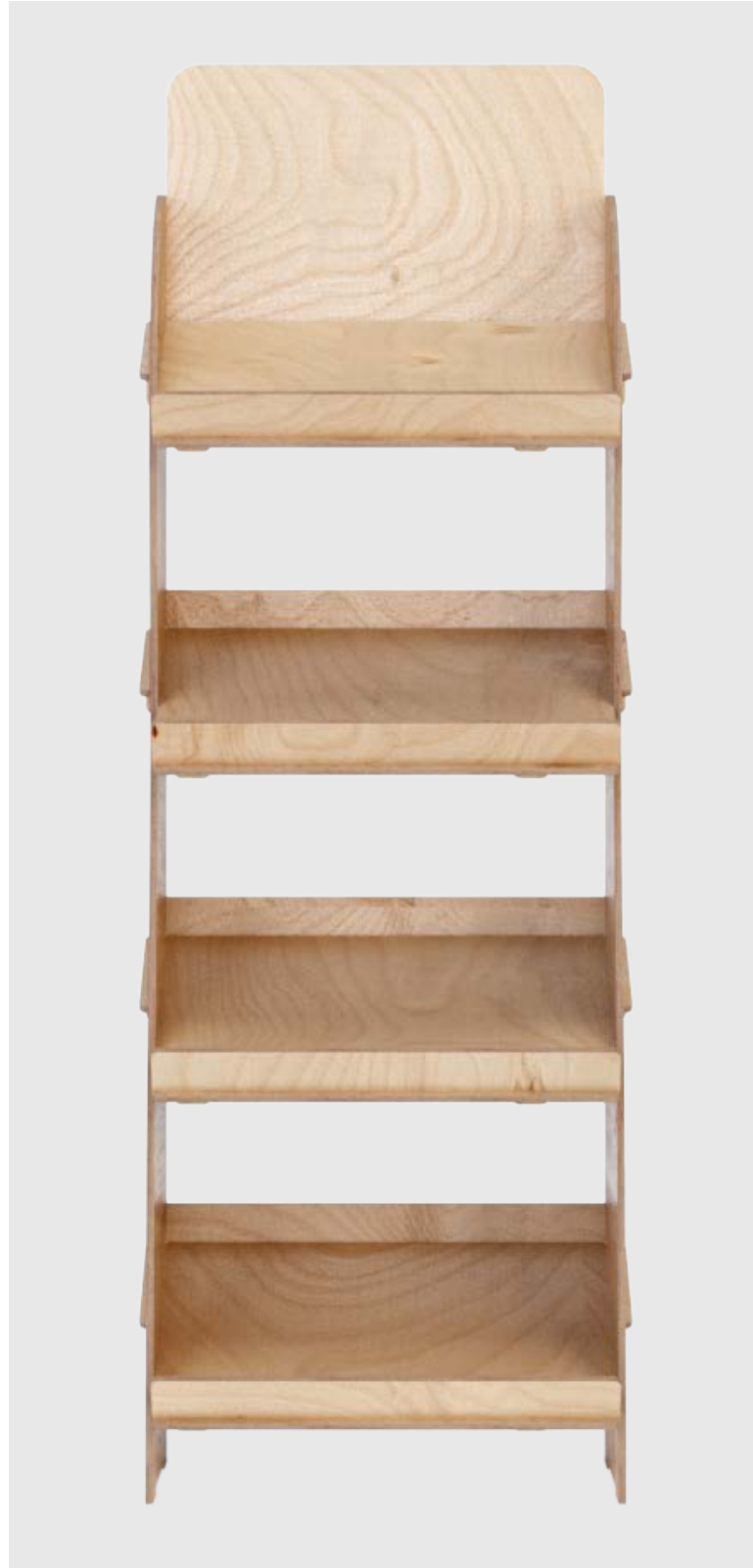

## Inclino

Floor Display with Forward-Inclined Shelves for Enhanced Product Visibility

Designed with forward-inclined shelves, this floor display ensures that your products are easily visible and attractively presented. It's an ideal solution for retail spaces, offering both functionality and style.

Crafted from FSC-certified wood sourced from sustainable forests, it provides an eco-friendly and responsible way to promote your brand.

With its simple interlocking assembly, this display offers a quick and hassle-free setup, saving you time. Its lightweight wooden construction makes it easy to move and position wherever needed.

**Material:**

- Eucalyptus 9 mm

**Weight:**

11 kg

**Package (WxDxH):**

160x45x6 cm

**Customization:**

- Painting
- Graphic printing

So **light**  
So **adjustable**  
So **sustainable**



# Ivy

360-Degree Floor Display – Ideal for Accessories, Gifts, and Small Clothing Items

Increase your product visibility with this 360-degree floor display, designed to showcase your accessories, gifts, or small clothing items from every angle. Its practical and functional design makes it a perfect addition to retail stores, pop-up shops, or trade show booths. Crafted from FSC-certified wood sourced from sustainable forests, it's an ecofriendly and responsible choice for promoting your brand. The quick interlocking assembly ensures hassle-free setup, saving you time and effort. Plus, its lightweight wooden structure makes it easy to move and position wherever you need it.

**Material:**

- Eucalyptus 9-15 mm

**Weight:**

9 kg

**Package (WxDxH):**

160x60x6 cm

**Customization:**

- Painting
- Graphic printing

So **light**  
So **adjustable**  
So **sustainable**



## Libre

Minimalist Floor Display – Perfect for Showcasing Gifts Articles  
 Designed to keep the focus on your products, this minimalist floor display is ideal for the gift item sector. Its clean, modern design enhances product visibility, making it a stylish addition to any retail space or trade show.

Crafted from FSC-certified wood sourced from sustainable forests, it's an eco-friendly and innovative way to promote your brand.

The quick installation via an interlocking system requires minimal effort, saving you valuable time. Plus, its lightweight wooden construction makes it easy to transport and position wherever it's needed.

**Material:**

- Eucalyptus 9-15 mm

**Weight:**

9 kg

**Package (WxDxH):**

160x45x6 cm

**Customization:**

- Painting
- Graphic printing

So **light**  
 So **adjustable**  
 So **sustainable**

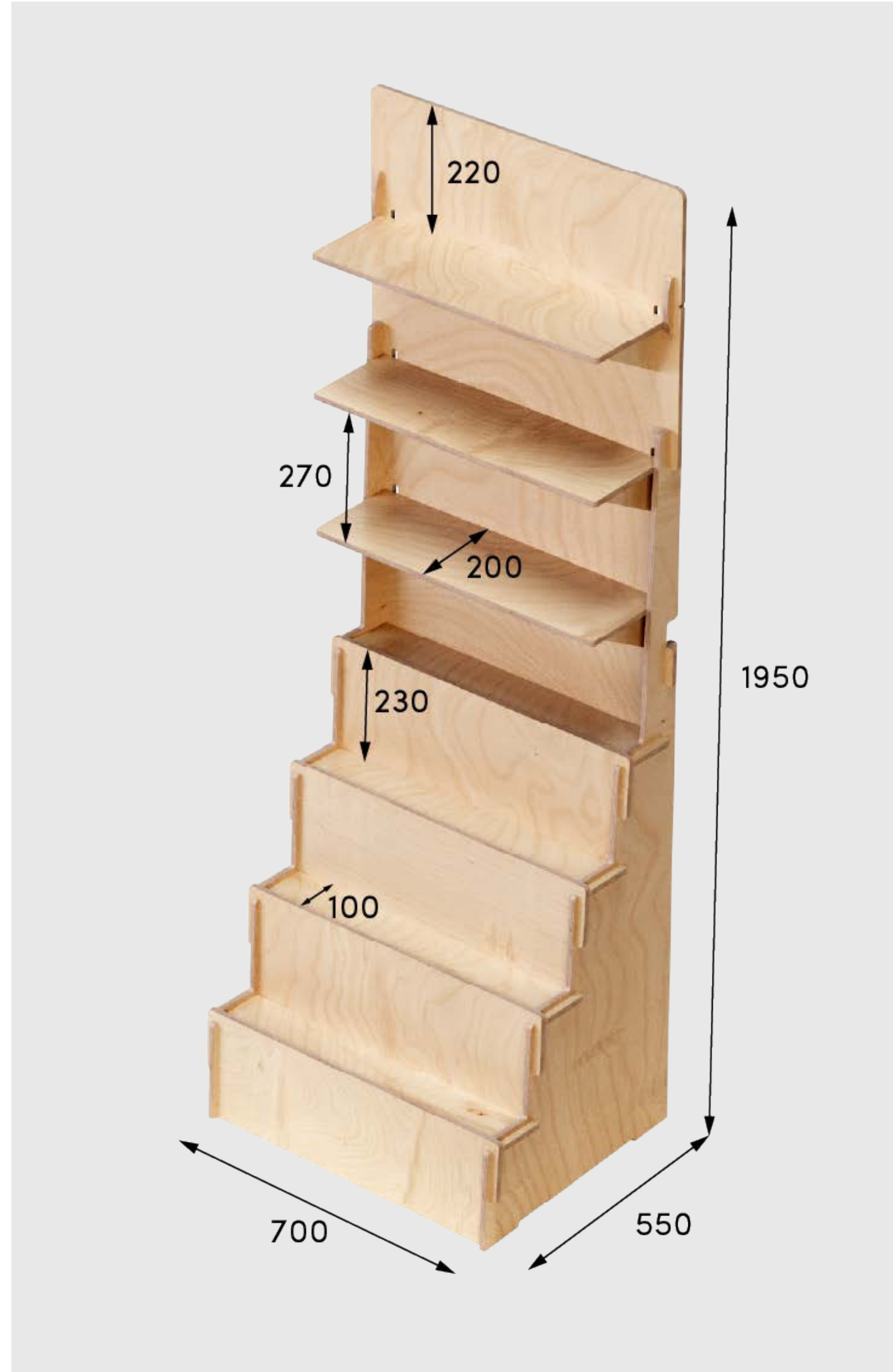
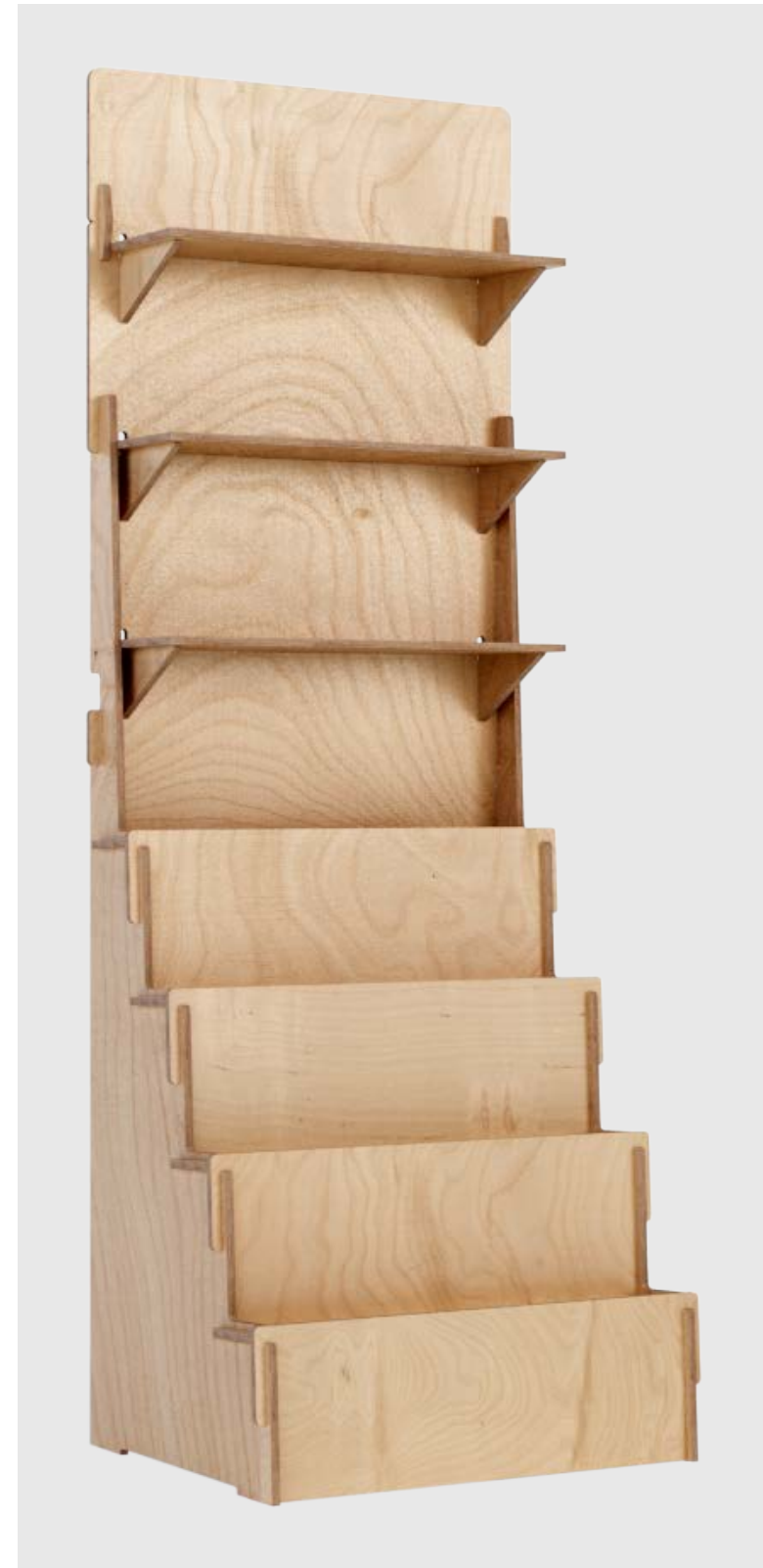
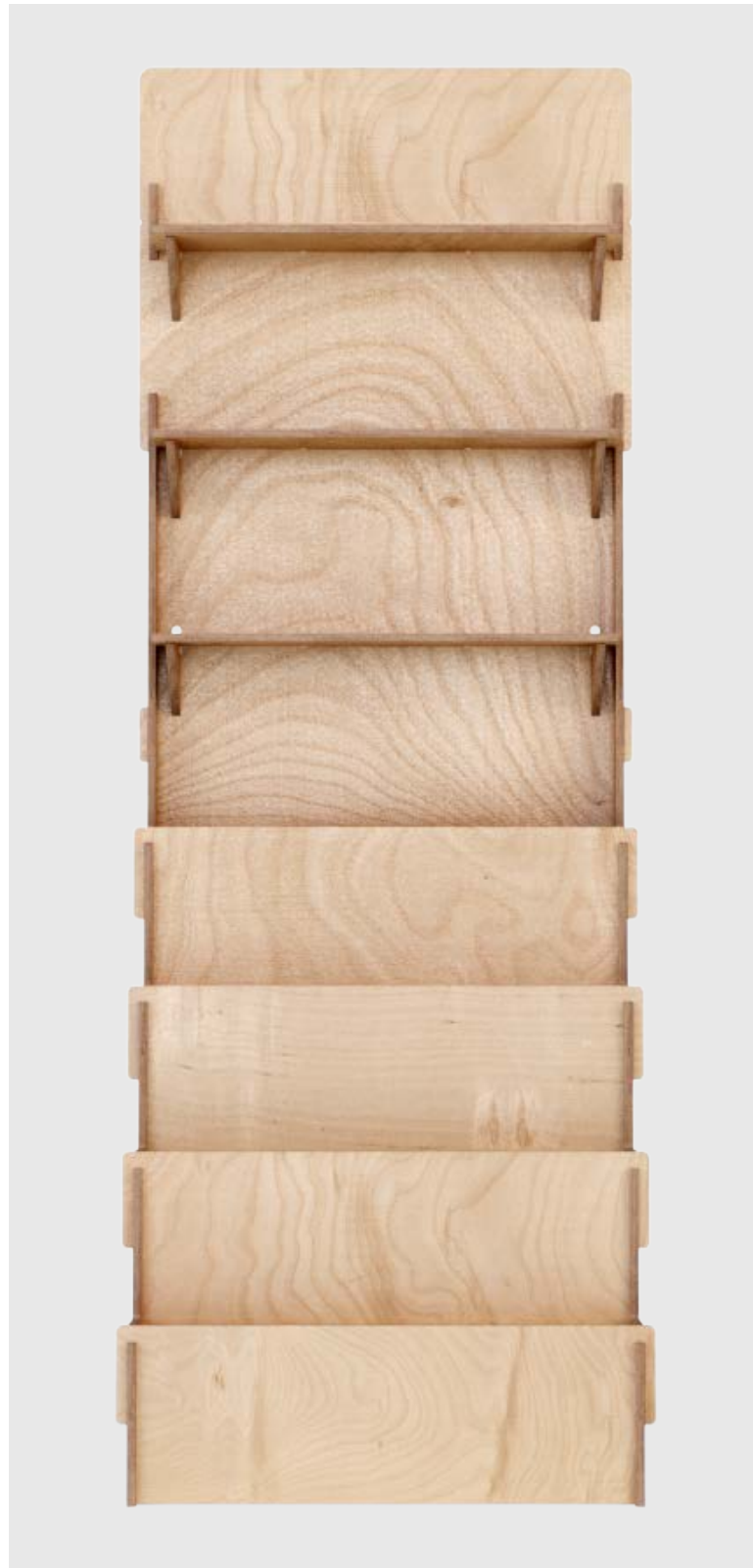

## Libro XL

With its generous dimensions and multiple shelves, this display system is perfect for showcasing stationery items like planners, agendas, and books. Its clean and natural design makes it an excellent choice for retail stores, bookstores, or trade shows.

Crafted from FSC-certified wood sourced from sustainable forests, this display offers a unique and responsible way to promote your brand.

With its simple interlocking assembly, setup takes minimal time and effort. Plus, its lightweight construction makes it easy to move and reposition, providing flexibility wherever it's needed.

**Material:**

- Eucalyptus 12 mm

**Weight:**

20 kg

**Package (WxDxH):**

160x45x6 cm

**Customization:**

- Painting
- Graphic printing

So **light**  
So **adjustable**  
So **sustainable**

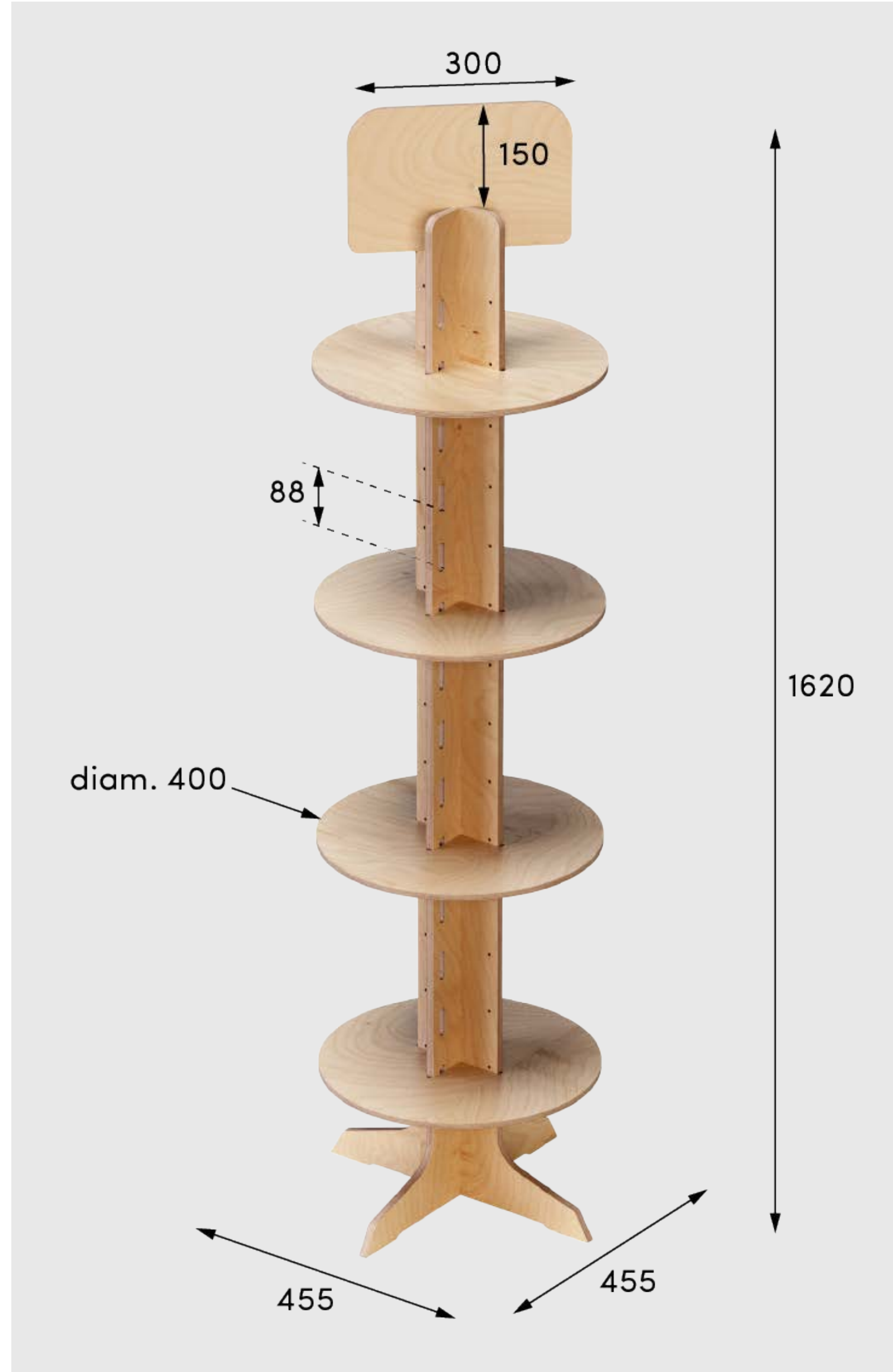

## Ria

Combining elegance and functionality, this display features adjustable shelves and 360-degree visibility, ensuring your products are properly stored. Its compact design makes it a perfect addition to retail stores, pop-ups, or trade shows.

Crafted from FSC-certified wood sourced from sustainable forests, it offers an eco-friendly solution for showcasing and promoting your brand.

It is developed for an easy interlocking assembly, while the lightweight build allows for effortless install and removal.

**Material:**

- Eucalyptus 9 mm

**Weight:**

6 kg

**Package (WxDxH):**

160x60x6 cm

**Customization:**

- Painting
- Graphic printing

So **light**  
So **adjustable**  
So **sustainable**

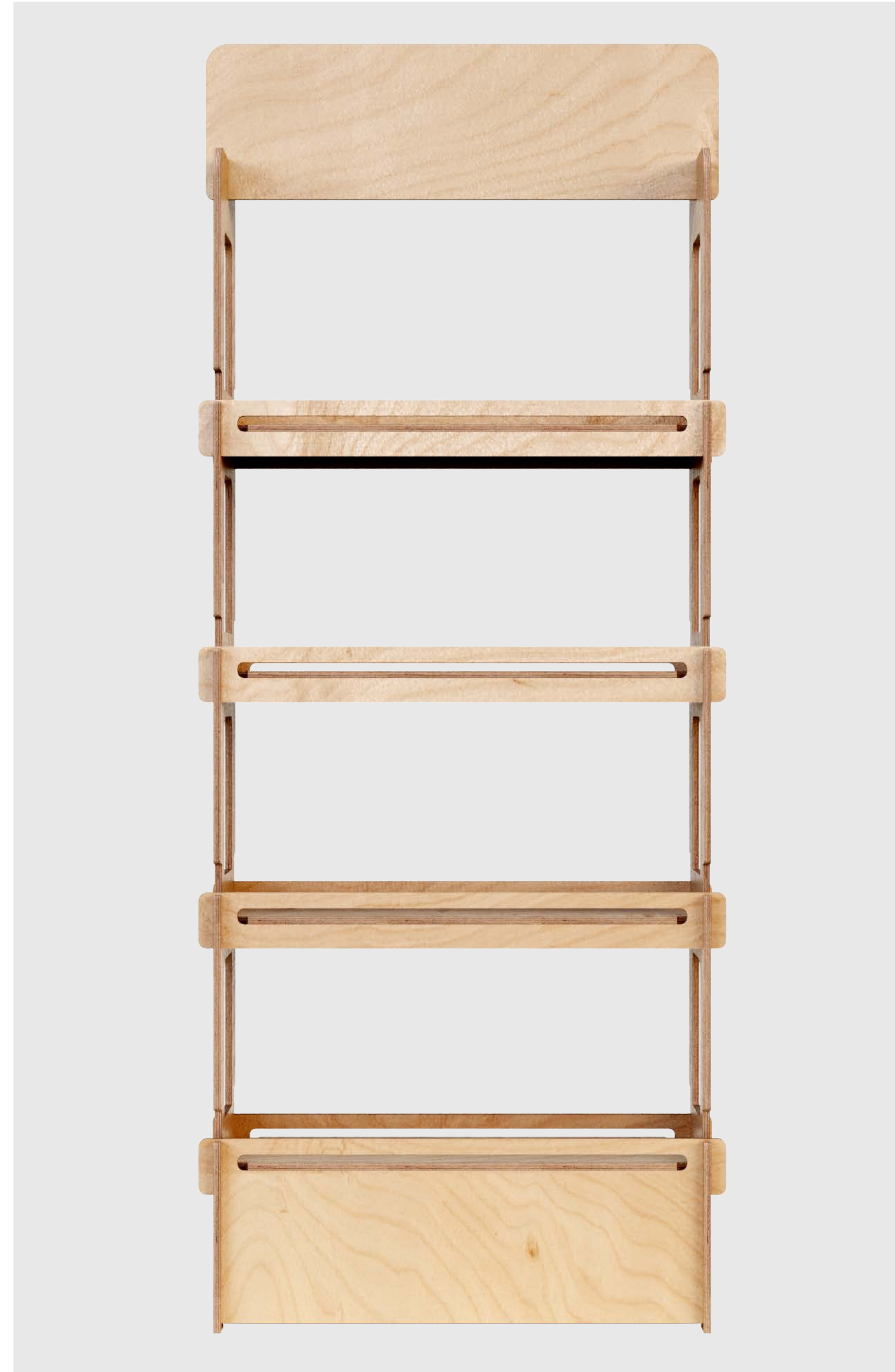

## Market

With its sleek, minimalist design, this display system is the perfect choice for showcasing products in the food and beverage industry.

Whether you are planning to exhibit gourmet treats, specialty drinks, or artisanal products, this elegant display enhances their presentation effectively.

Crafted from FSC-certified wood sourced from sustainable forests, it offers an eco-friendly and responsible way to promote your brand.

The quick interlocking assembly ensures hassle-free setup, saving you time and effort. Its lightweight construction makes it easy to transport and position wherever it's needed, providing flexibility for retail spaces, markets, or trade shows.

So **light**  
So **adjustable**  
So **sustainable**

**MARKET\_400**

**MARKET\_600**

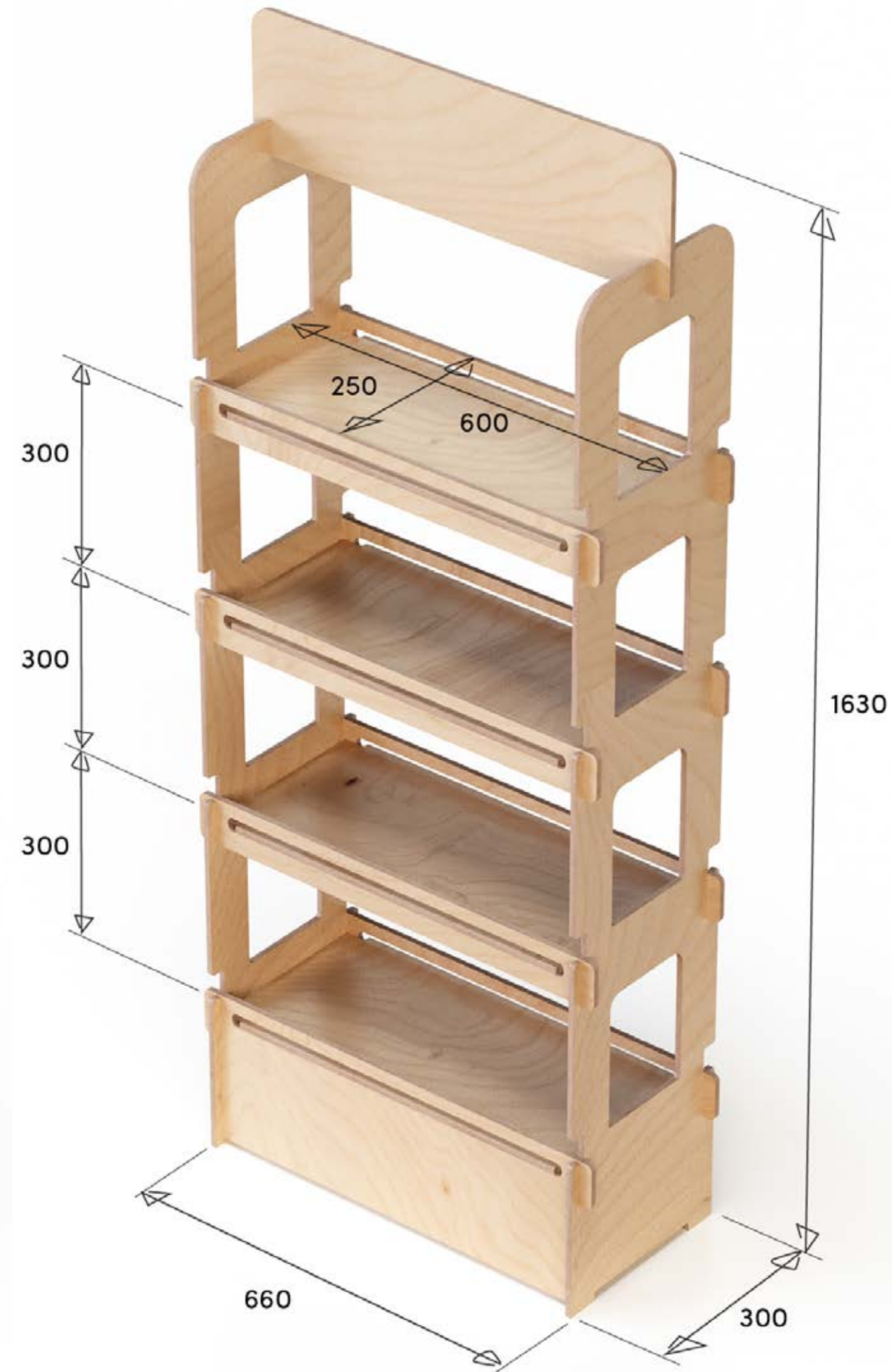
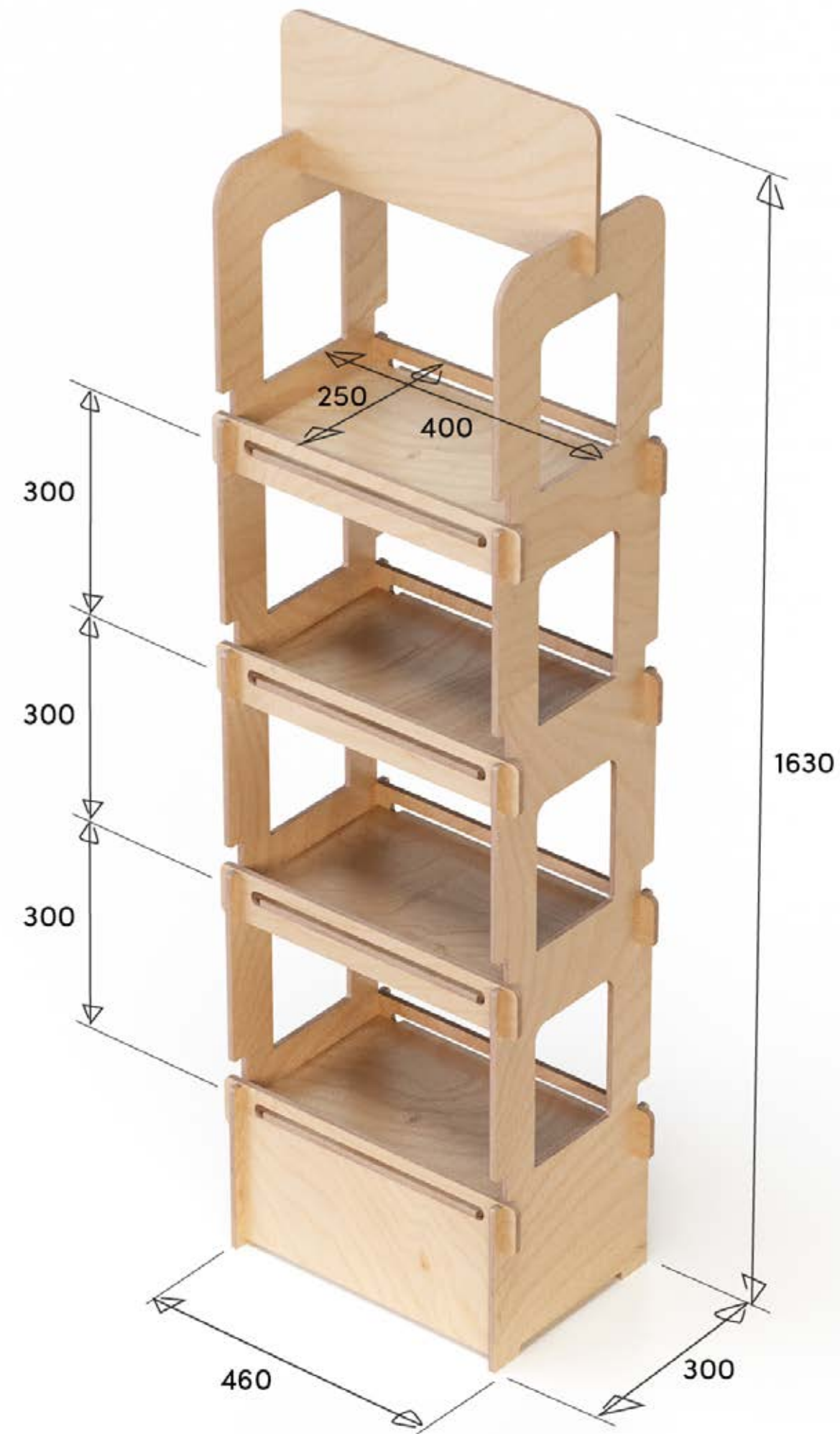

**Material:**

- Eucalyptus 9mm

**Weight:**

Market\_400: 8 kg

Market\_600: 11 kg

**Package (WxDxH):**

Market\_400: 160x30x6

Market\_600: 160x36x6

**Customization:**

- Painting
- Graphic printing

So **light**  
So **adjustable**  
So **sustainable**

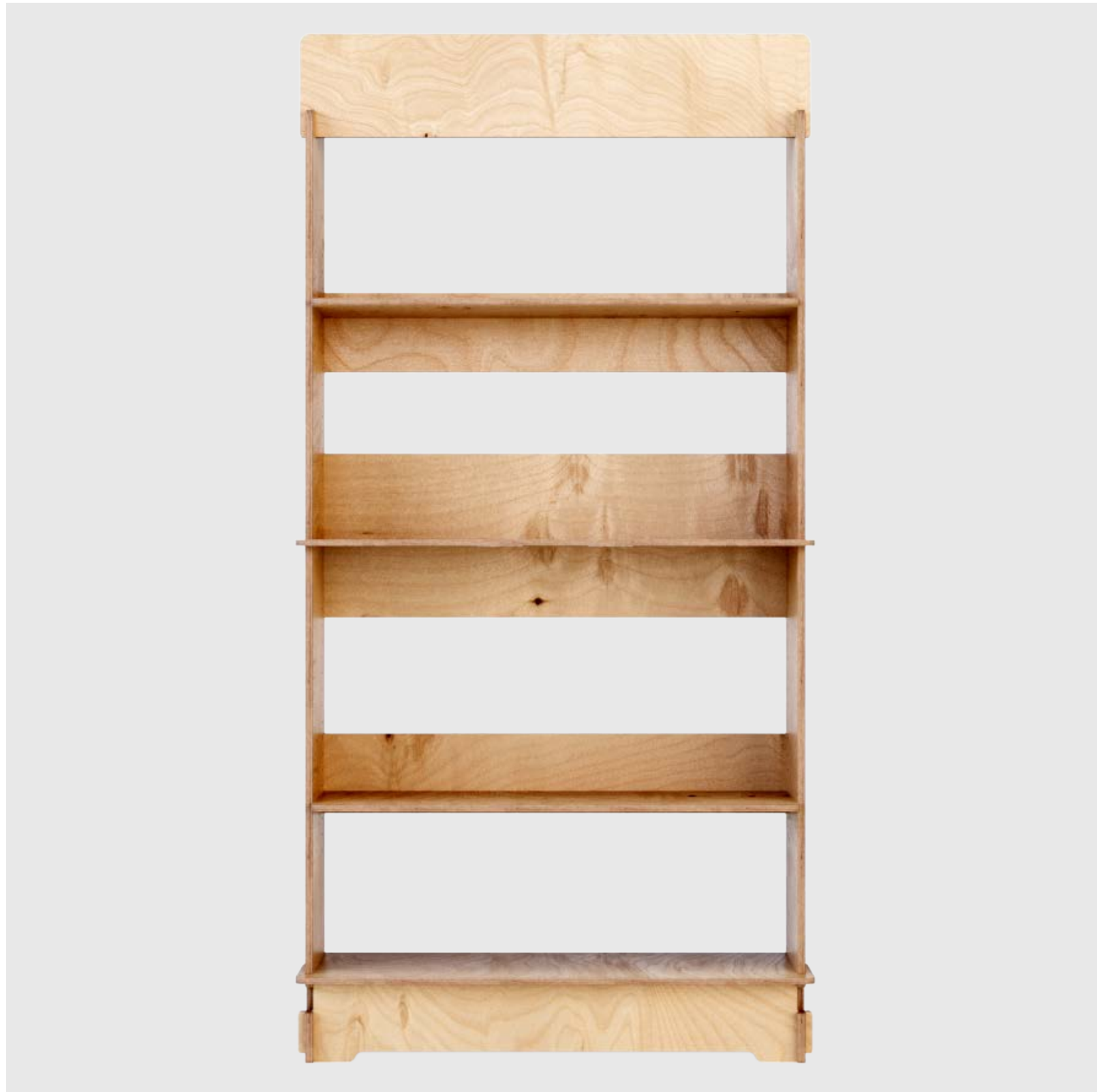

## Move

Designed with generous dimensions, this display system is perfect for showcasing a wide range of stationery products like notebooks, planners, and books.

Its sleek and modern design ensures your products stand out on the shelves whether they are in retail stores, bookstores, or trade show booths.

Crafted from FSC-certified wood sourced from sustainable forests, it's an efficient and responsible solution for promoting your own brand.

With an easy interlocking assembly, setup is effortless and efficient, saving you time and labor.

Plus, its lightweight construction allows for easy transport and flexible placement wherever it's needed.

So **light**  
So **adjustable**  
So **sustainable**

**MOVE**



**MOVE\_XL**



**Material:**

- Eucalyptus 12mm

**Weight:**

Move: 21 kg

Move\_XL: 25 kg

**Package (WxDxH):**

Move: 200x74x5

Move\_XL: 200x74x8

**Customization:**

- Painting

- Graphic printing

So **light**  
So **adjustable**  
So **sustainable**



## Move C

Elegant Compact Display with Adjustable Shelves and 360-Degree Visibility

This sophisticated display features adjustable shelves and 360-degree visibility to make full use of the space, making it an excellent choice for showcasing a variety of products. Its compact dimensions ensure it fits seamlessly into any retail space, popup shop, or trade show booth. Crafted from FSC-certified wood sourced from sustainable forests, this display offers a sustainable and responsible way to promote your brand.

With its quick interlocking assembly, setting up is effortless and time-saving. The lightweight construction makes it easy to transport and position wherever you need it.

**Material:**

- Eucalyptus 12 mm

**Weight:**

29 kg

**Package (WxDxH):**

120x75x10 cm

**Customization:**

- Painting
- Graphic printing

So **light**  
So **adjustable**  
So **sustainable**

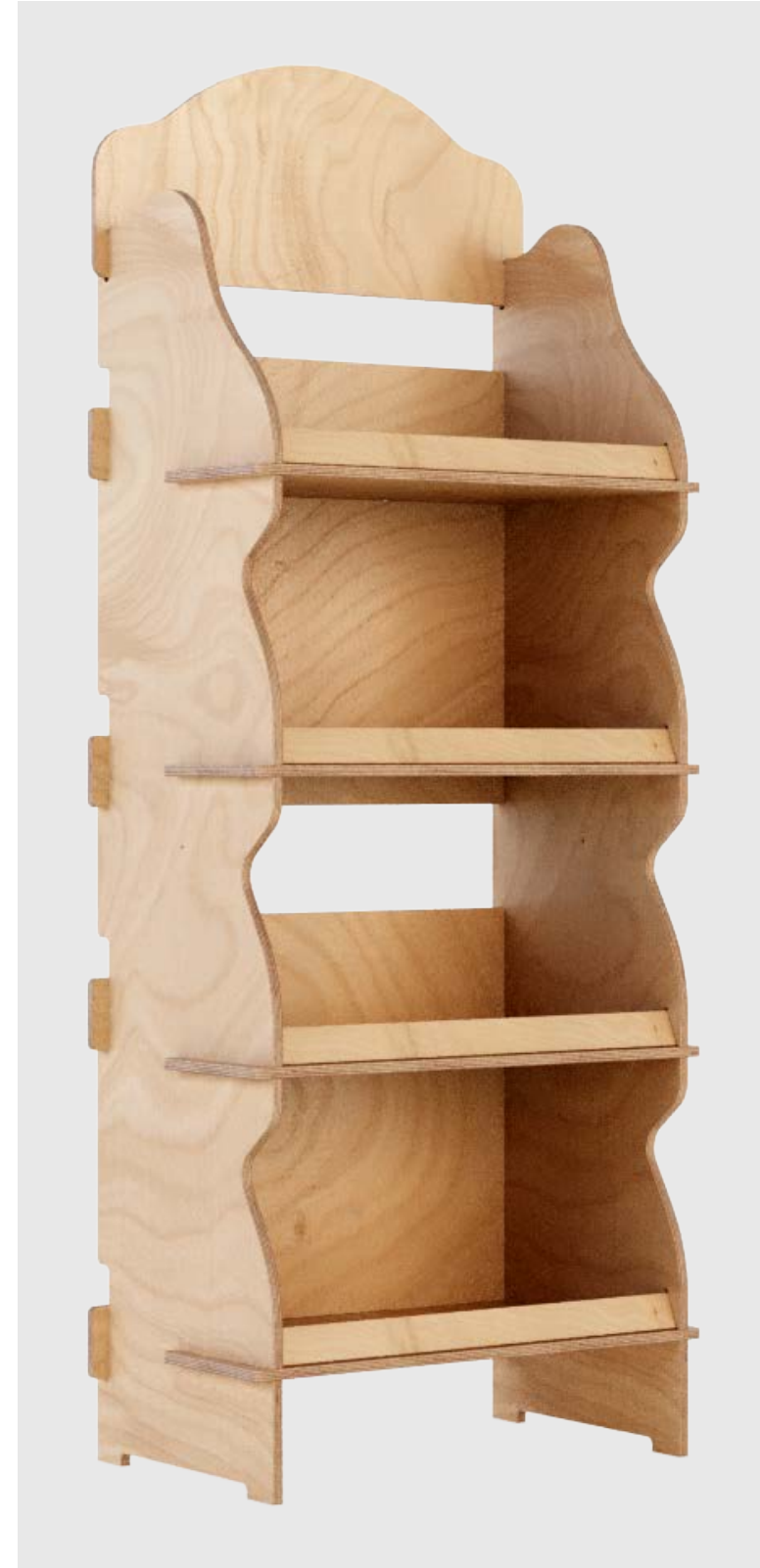
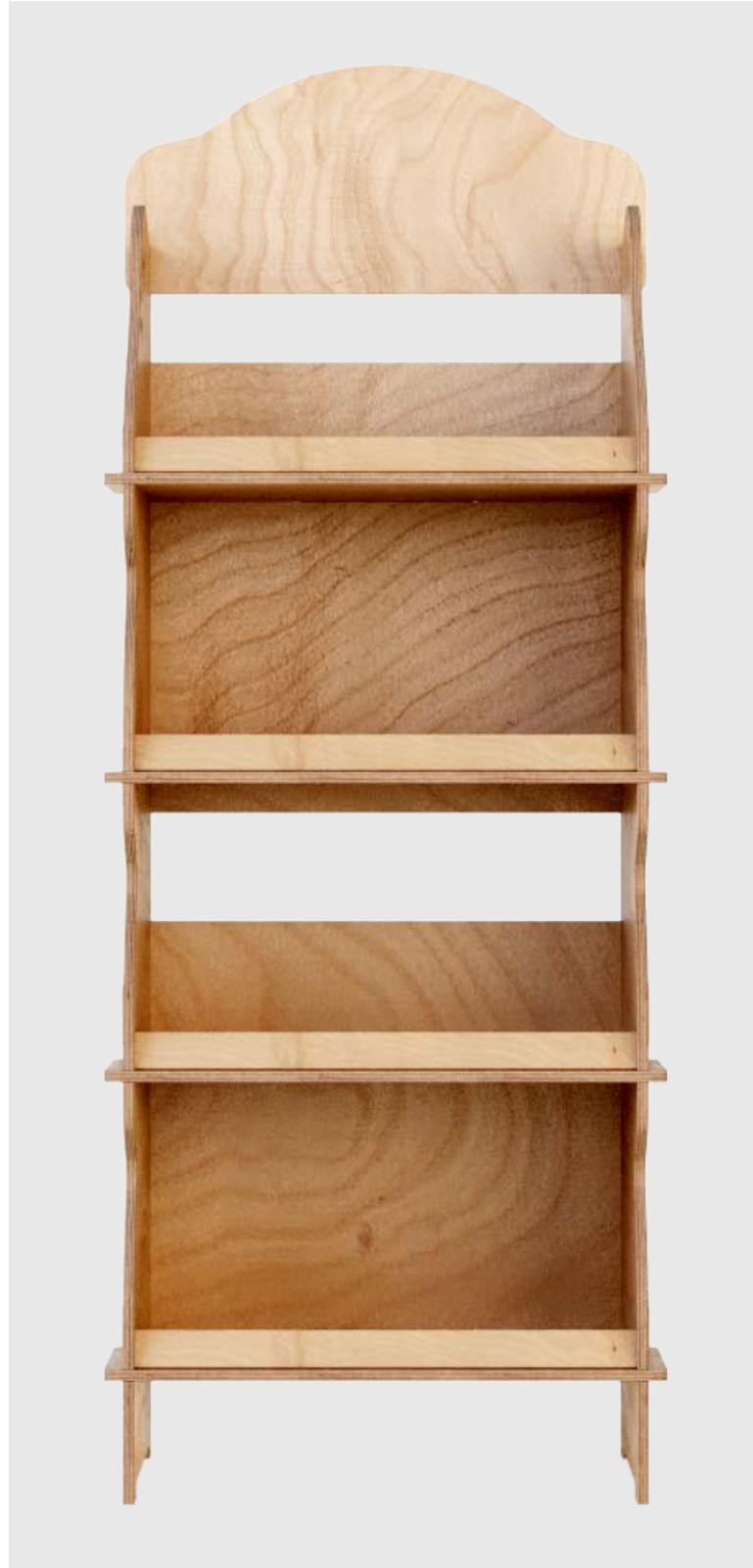

## Pet

With its clean, minimalist design, this display system is an ideal choice for showcasing products in the food and beverage industry. From gourmet treats to specialty drinks, it enhances product presentation while maintaining a sleek and modern aesthetic. Crafted from FSC-certified wood sourced from sustainable forests, it provides an eco-friendly and responsible way to promote your brand.

Featuring an easy interlocking assembly, it's designed with easy setup in mind, saving you time and effort. The lightweight wooden construction ensures effortless transport and flexible placement possibilities, making it a versatile choice for retail spaces, markets, or trade shows.

**Material:**

- Eucalyptus 12 mm

**Weight:**

18 kg

**Package (WxDxH):**

160x45x6 cm

**Customization:**

- Painting
- Graphic printing

So **light**  
So **adjustable**  
So **sustainable**

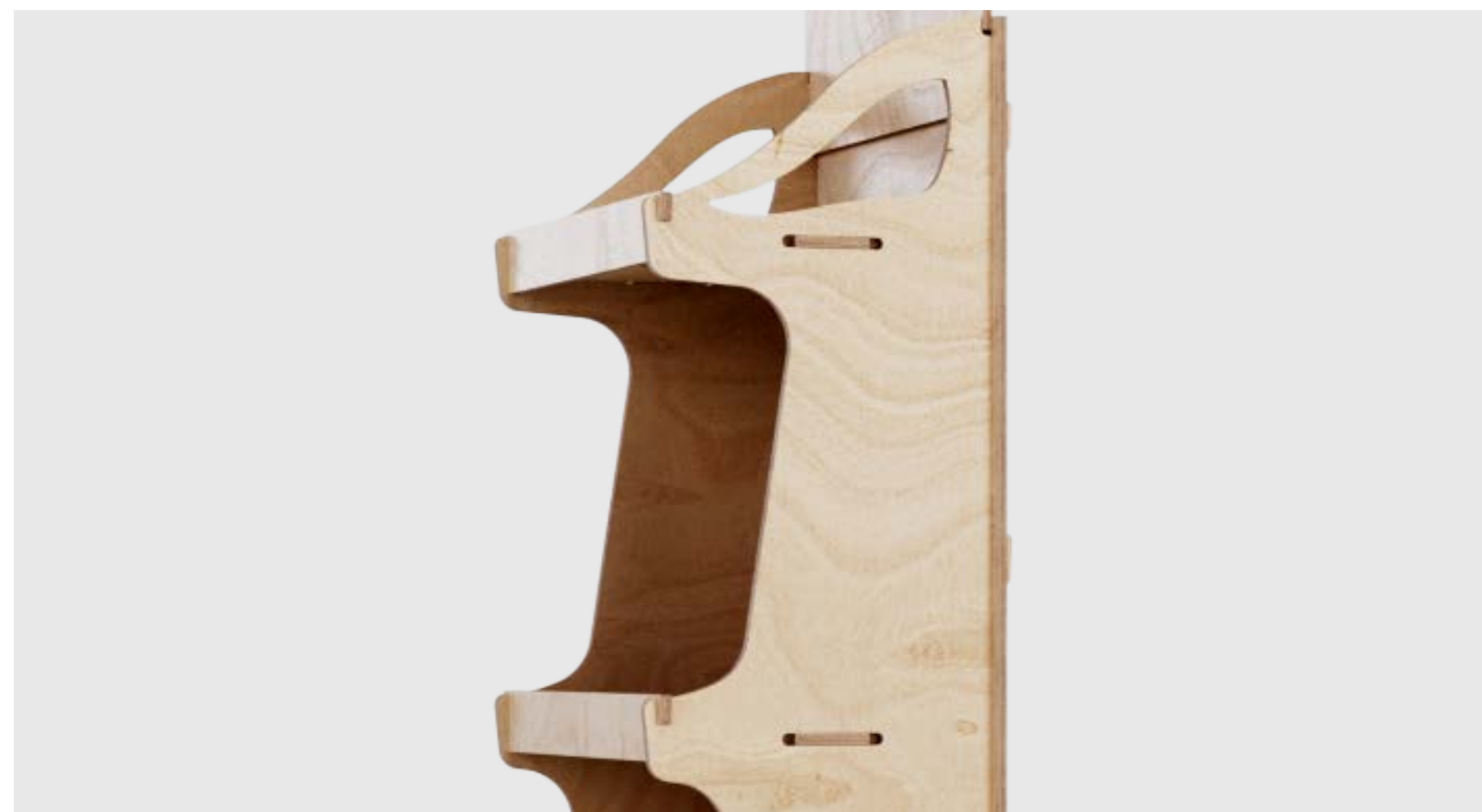
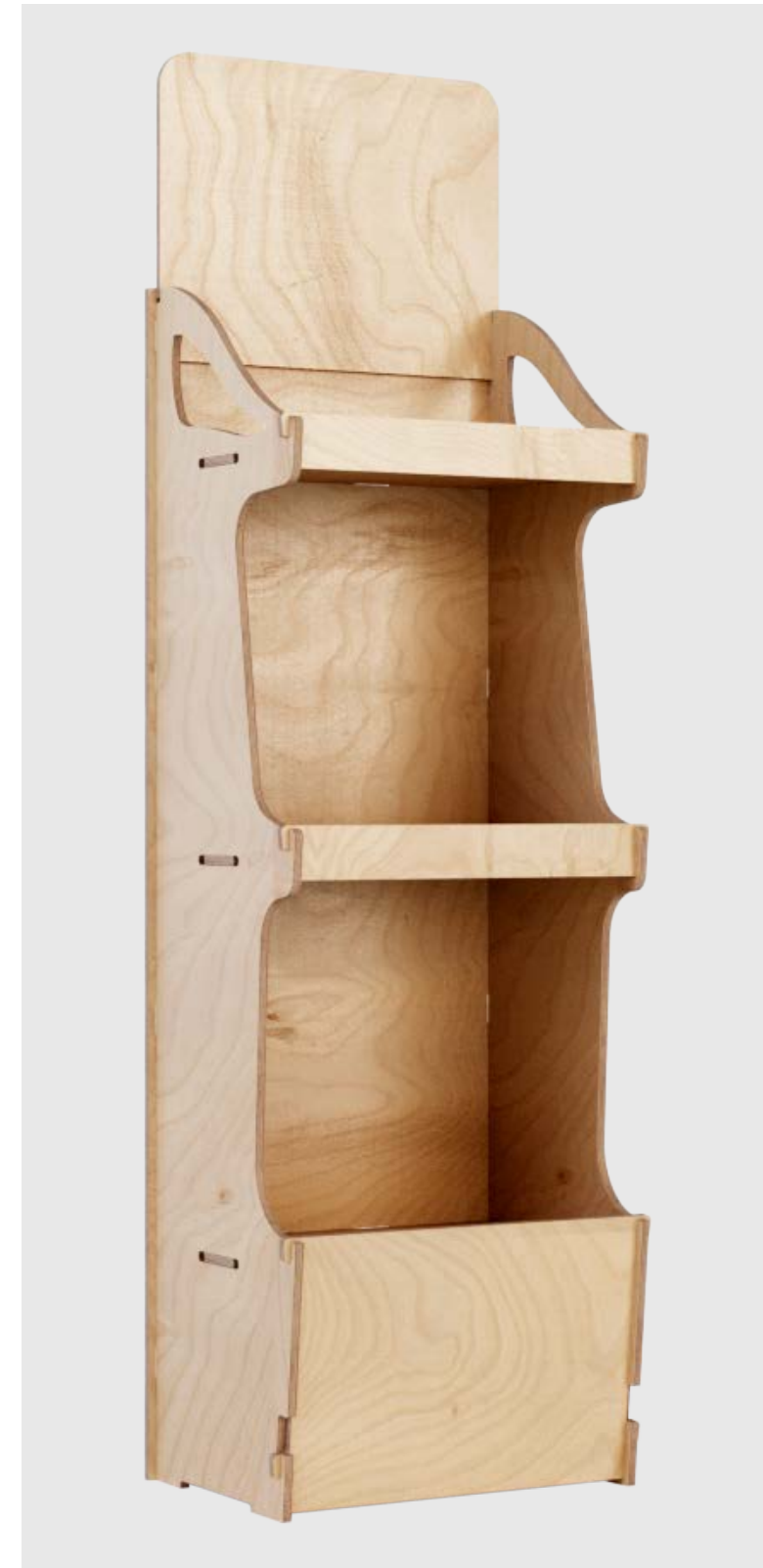
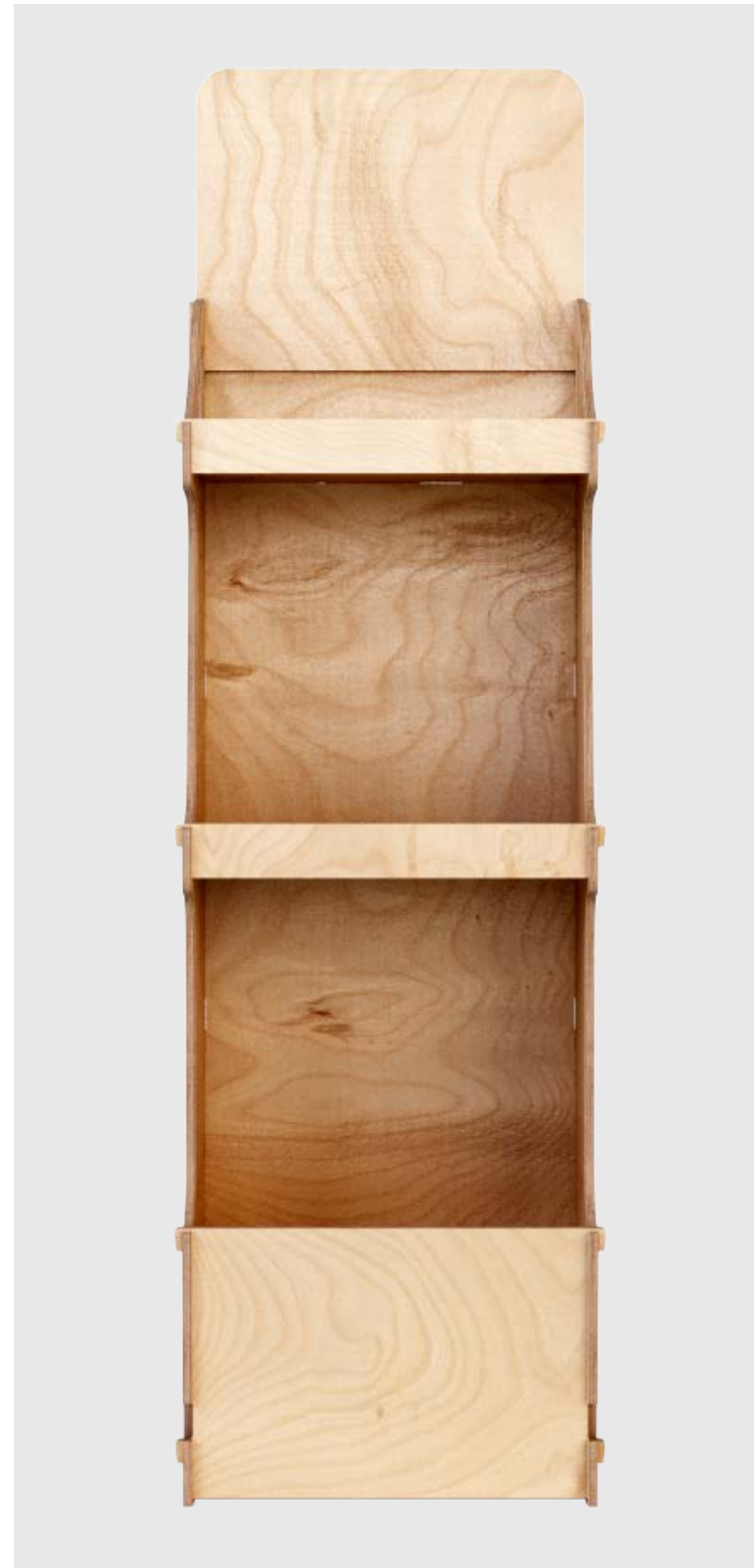

## Silvestro

With its sleek, minimalist design, this display system is perfect for showcasing products in the food and beverage industry. Whether you're displaying artisanal goods, packaged snacks, or bottled beverages, it provides an elegant solution to a practical need. Crafted from FSC-certified wood sourced from sustainable forests, it's an eco-friendly and responsible way to showcase and promote your brand. The quick interlocking assembly requires minimal effort, saving you time and hassle. Plus, its lightweight wooden construction makes it easy to transport and position wherever you need. Promote your products with style and sustainability!

**Material:**

- Eucalyptus 9 mm

**Weight:**

6 kg

**Package (WxDxH):**

160x50x6 cm

**Customization:**

- Painting
- Graphic printing

So **light**  
So **adjustable**  
So **sustainable**

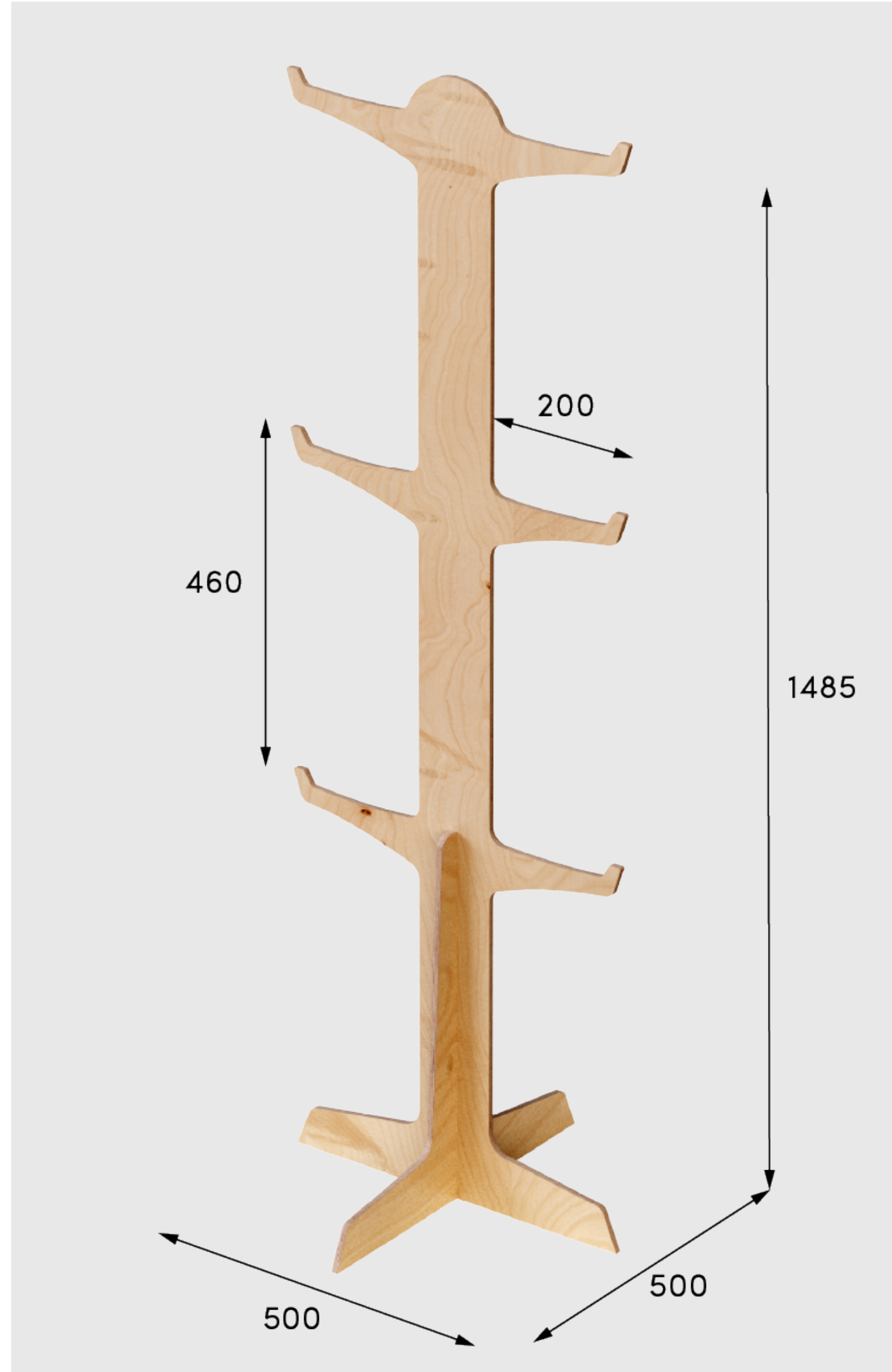

## Sol

With its clean, minimalist design, this display system is the ideal solution for showcasing handbags and accessories. From tote bags and handbags to backpacks and purses, it enhances product visibility while adding a touch of elegance to your space.

Crafted from FSC-certified wood sourced from sustainable forests, this display offers a stylish and sustainable way to present and promote your brand. The quick interlocking assembly requires minimal effort, saving you valuable time.

Plus, its lightweight wooden construction makes it easy to move and position wherever you need it.

**Material:**

- Eucalyptus 9 mm

**Weight:**

2 kg

**Package (WxDxH):**

160x60x6 cm

**Customization:**

- Painting
- Graphic printing

So **light**  
So **adjustable**  
So **sustainable**

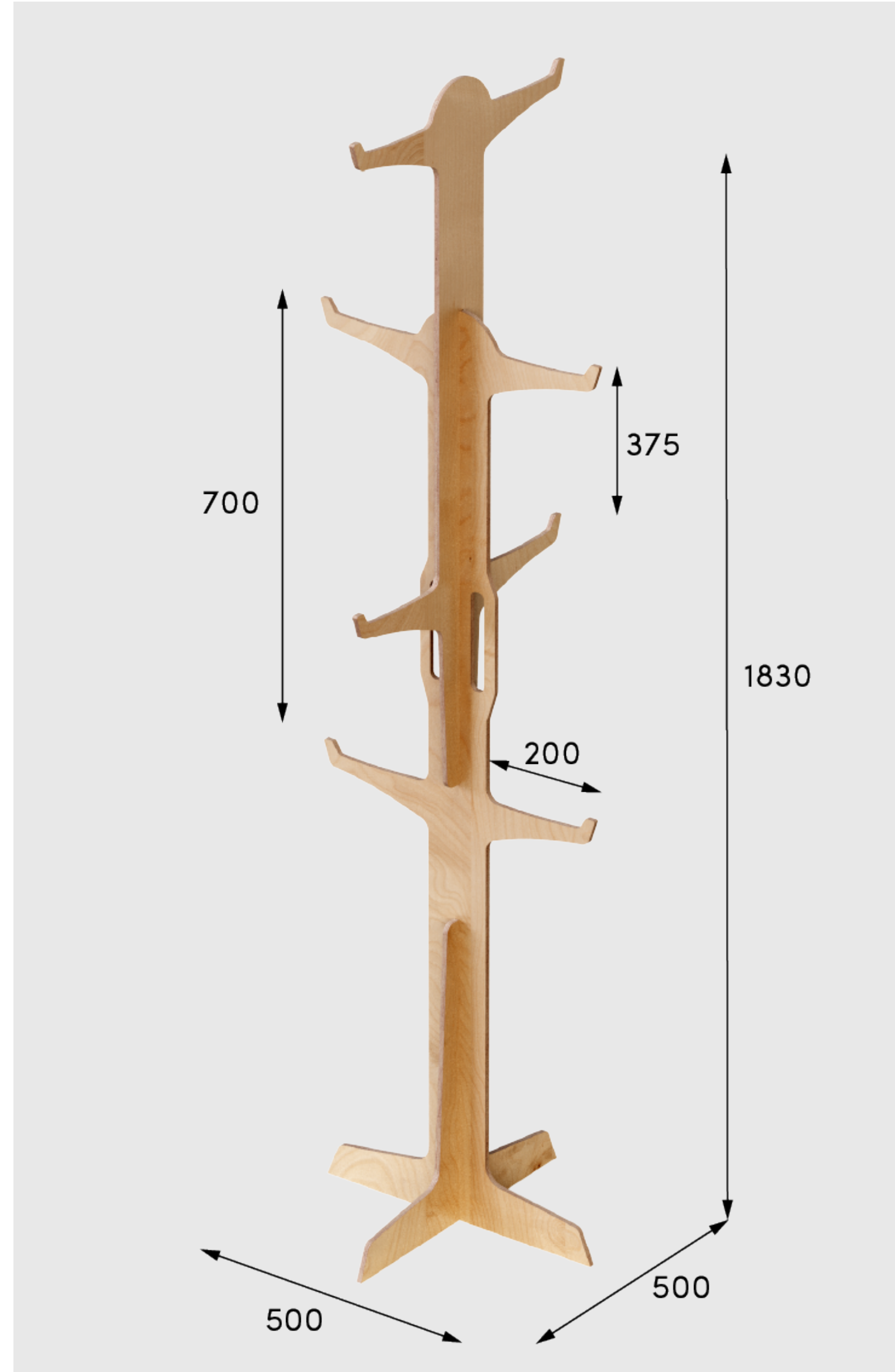

## Sol Max

With its sleek, minimalist design, this display system is perfect for properly showcasing beautiful handbags, from shoulder bags and backpacks to totes and purses.

Crafted from FSC-certified wood sourced from sustainably managed forests, it offers an eco-friendly and responsible way to present and promote your brand.

The easy interlocking assembly requires minimal effort, saving you valuable time, while the lightweight wooden construction makes it effortless to transport and store wherever needed.

**Material:**

- Eucalyptus 9 mm

**Weight:**

3 kg

**Package (WxDxH):**

160x60x6 cm

**Customization:**

- Painting
- Graphic printing

So **light**  
So **adjustable**  
So **sustainable**

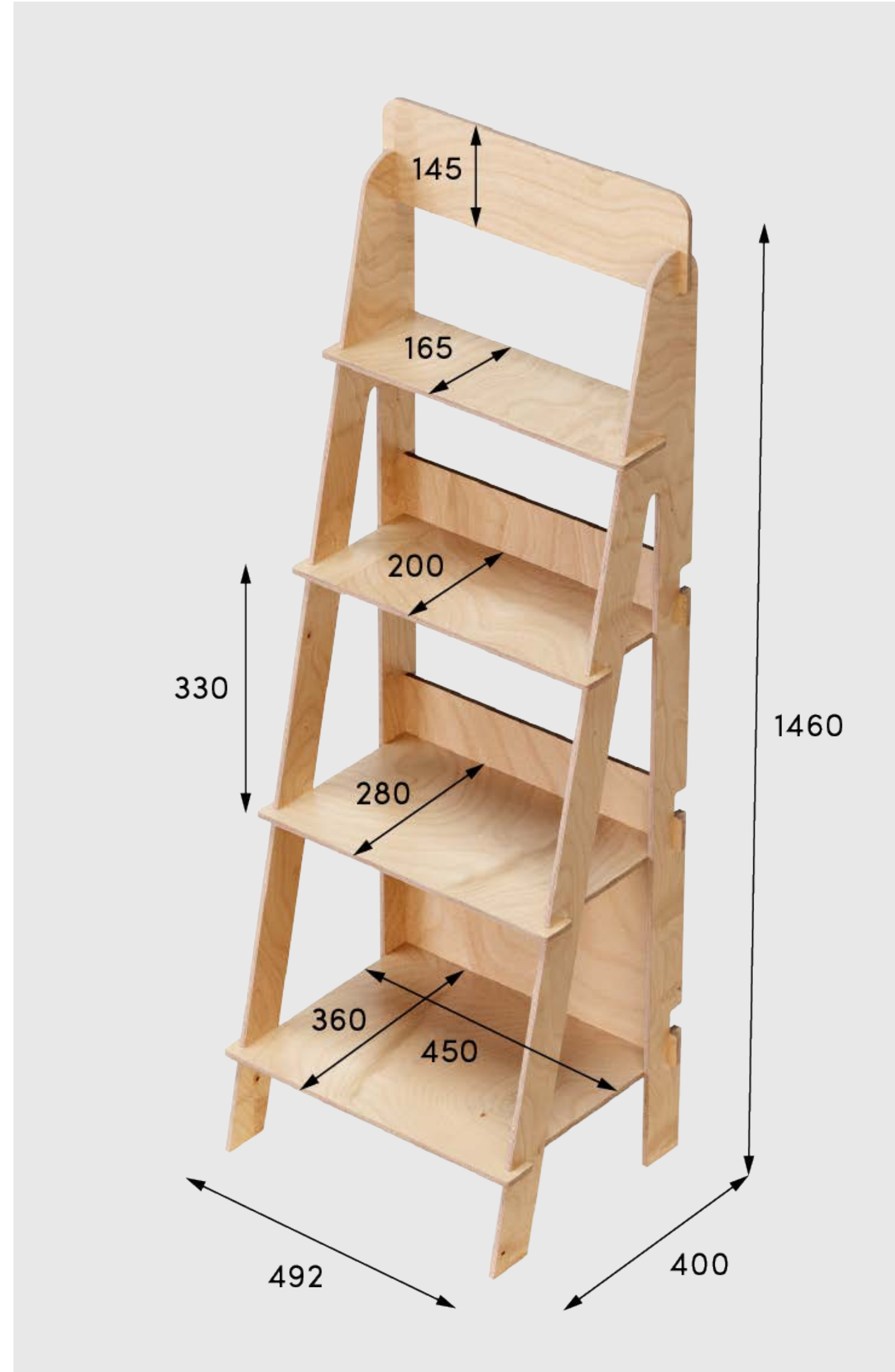
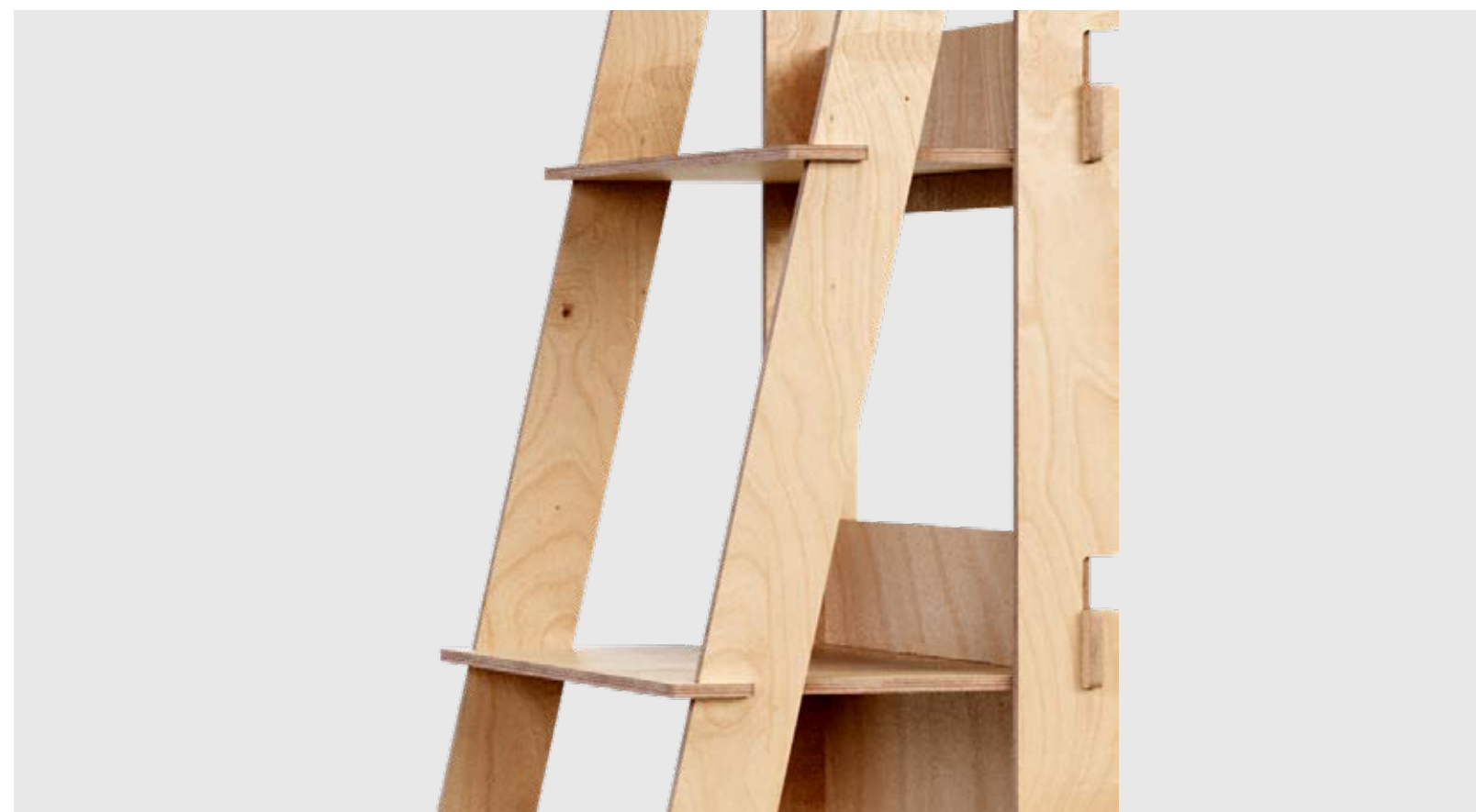
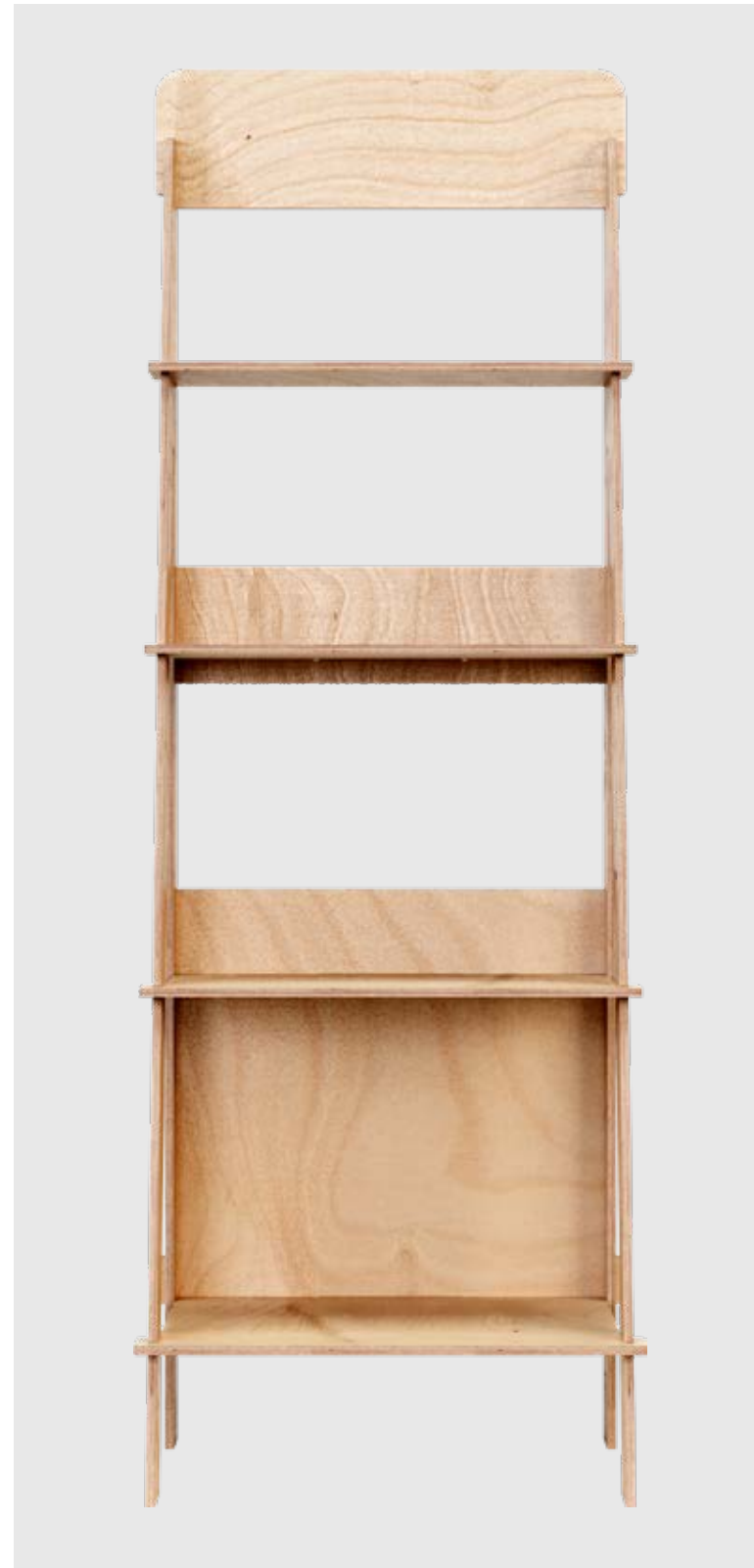

## Stairs

With its ladder-inspired design and multiple tiers, this display system is an ideal choice for highlighting gift and design products.

Crafted from FSC-certified wood sourced from sustainably managed forests, it offers an eco-friendly and elegant way to present and promote your brand.

The quick interlocking assembly requires minimal effort, saving you valuable time, while the lightweight wooden construction ensures an easy and secure installation process.

**Material:**

- Eucalyptus 9 mm

**Weight:**

6 kg

**Package (WxDxH):**

160x50x6 cm

**Customization:**

- Painting
- Graphic printing

So **light**  
So **adjustable**  
So **sustainable**

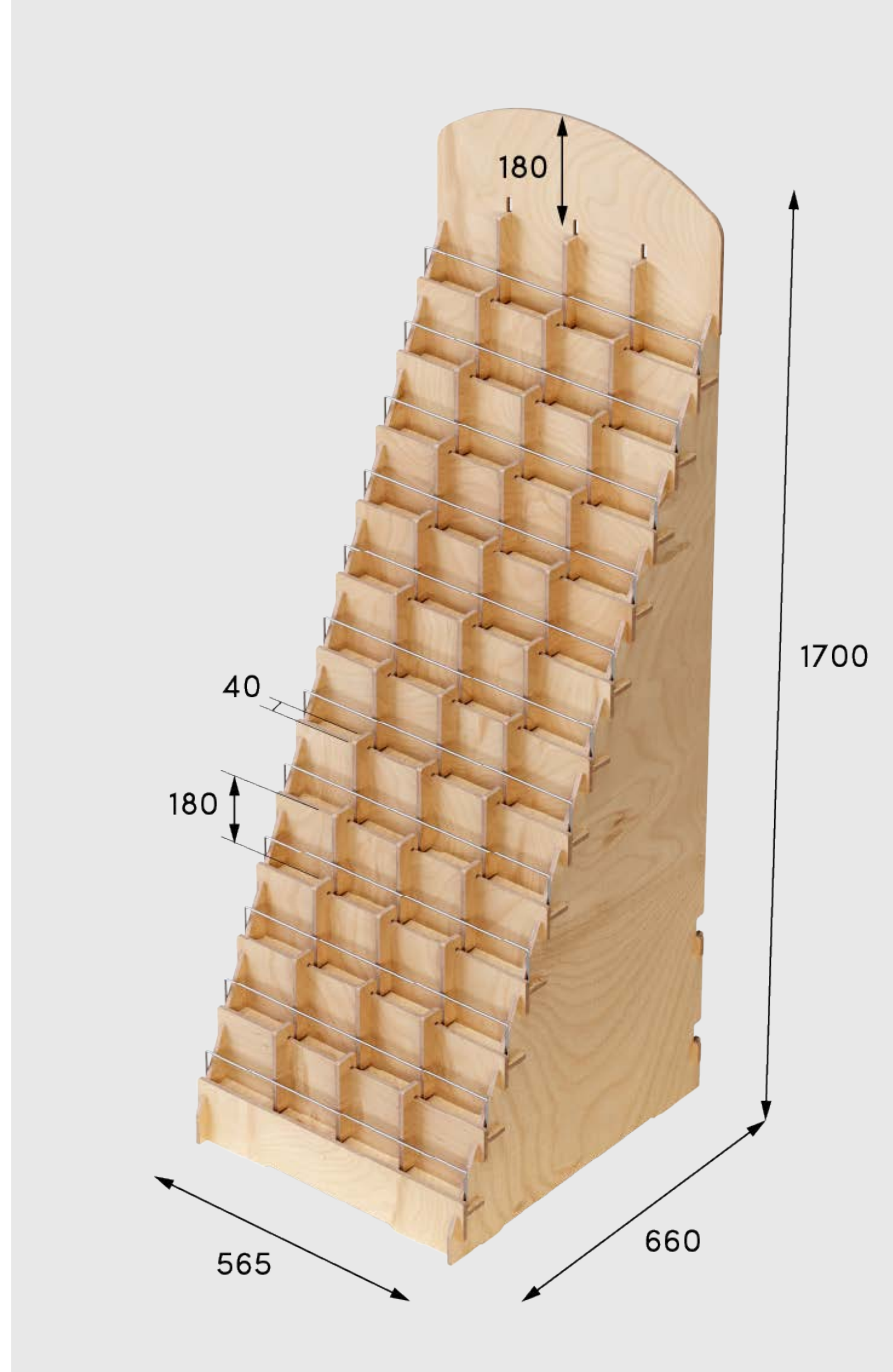

## Opus

Designed specifically to showcase greeting cards and other stationery products like notebooks and planners, this display combines functionality with style.

Crafted from FSC-certified wood sourced from sustainably managed forests, it offers an ecofriendly solution for presenting and promoting your brand.

With its quick interlocking assembly that requires minimal effort, you'll save valuable time.

The lightweight wooden construction makes it easy to move and position wherever you need it.

**Material:**

- Eucalyptus 9 mm

**Weight:**

18 kg

**Package (WxDxH):**

170x80x6 cm

**Customization:**

- Painting
- Graphic printing

So **light**  
So **adjustable**  
So **sustainable**



## Adapti

This versatile display stand features movable and tip-up shelves, offering maximum flexibility to showcase your products more effectively.

Crafted from FSC-certified wood sourced from sustainably managed forests, it provides a responsible and sustainable way to present and promote your brand.

The quick interlocking assembly ensures a hassle-free setup, saving you valuable time, while its lightweight wooden construction makes it easy to move and adjust as needed.

So **light**  
So **adjustable**  
So **sustainable**

**ADAPTI 400**

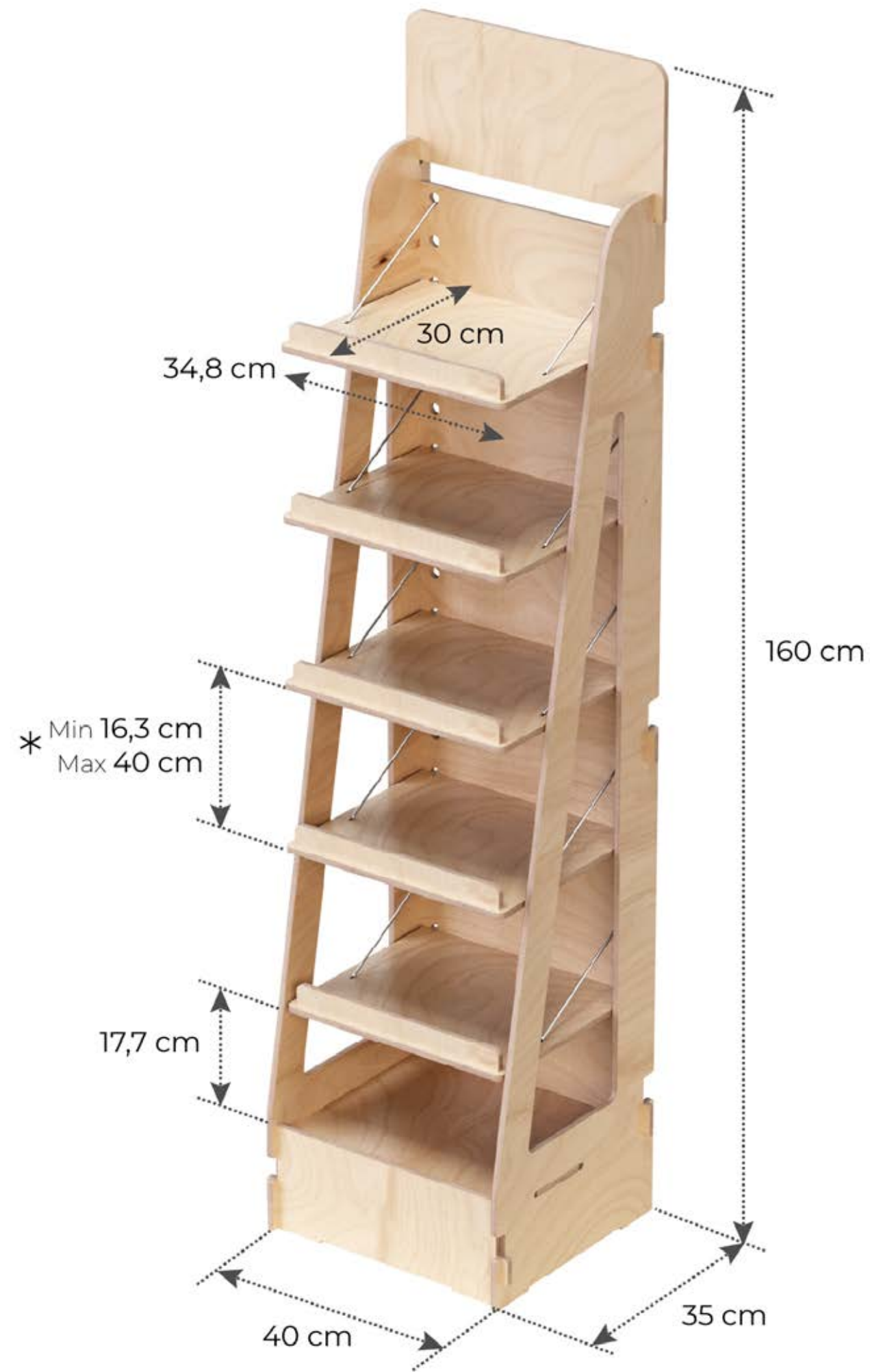

**ADAPTI 600**

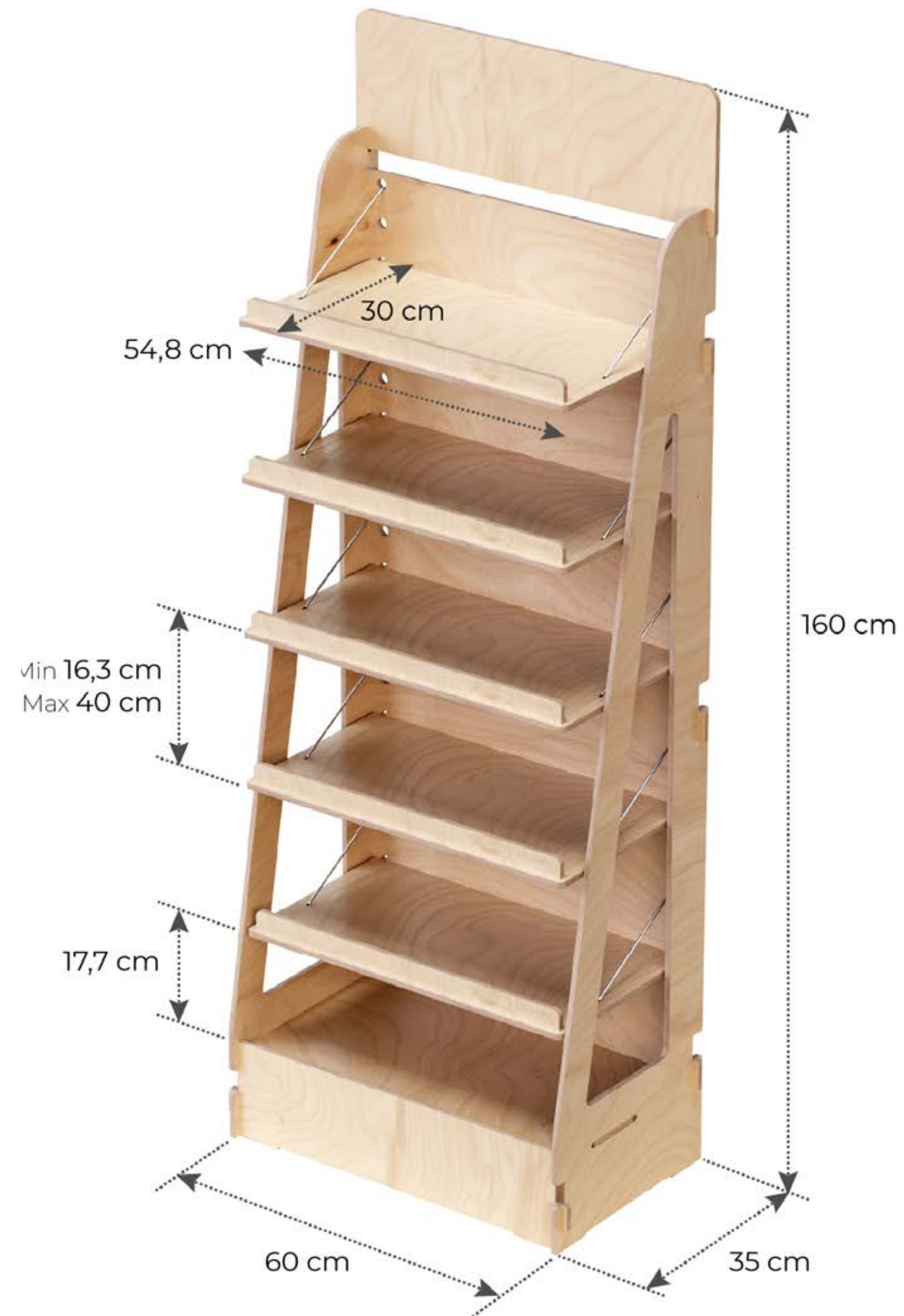

**Material:**

Eucalyptus 9mm

**Weight:**

Adapti 400: 11 kg

Adapti 600: 15 kg

**Package (WxDxH):**

160x45x6

**Customization:**

- Painting
- Graphic printing

So **light**  
So **adjustable**  
So **sustainable**



## Arbor

Featuring movable and tip-up shelves, this display stand offers maximum flexibility to present your products beautifully and efficiently.

Crafted from FSC-certified wood sourced from sustainably managed forests, it's an eco-conscious choice that reflects your commitment to sustainability.

The interlocking assembly ensures a quick and easy setup with minimal effort, saving you time and hassle.

Plus, its lightweight wooden construction makes it simple to move and position wherever you need it.

So **light**  
So **adjustable**  
So **sustainable**

**ARBOR 400**

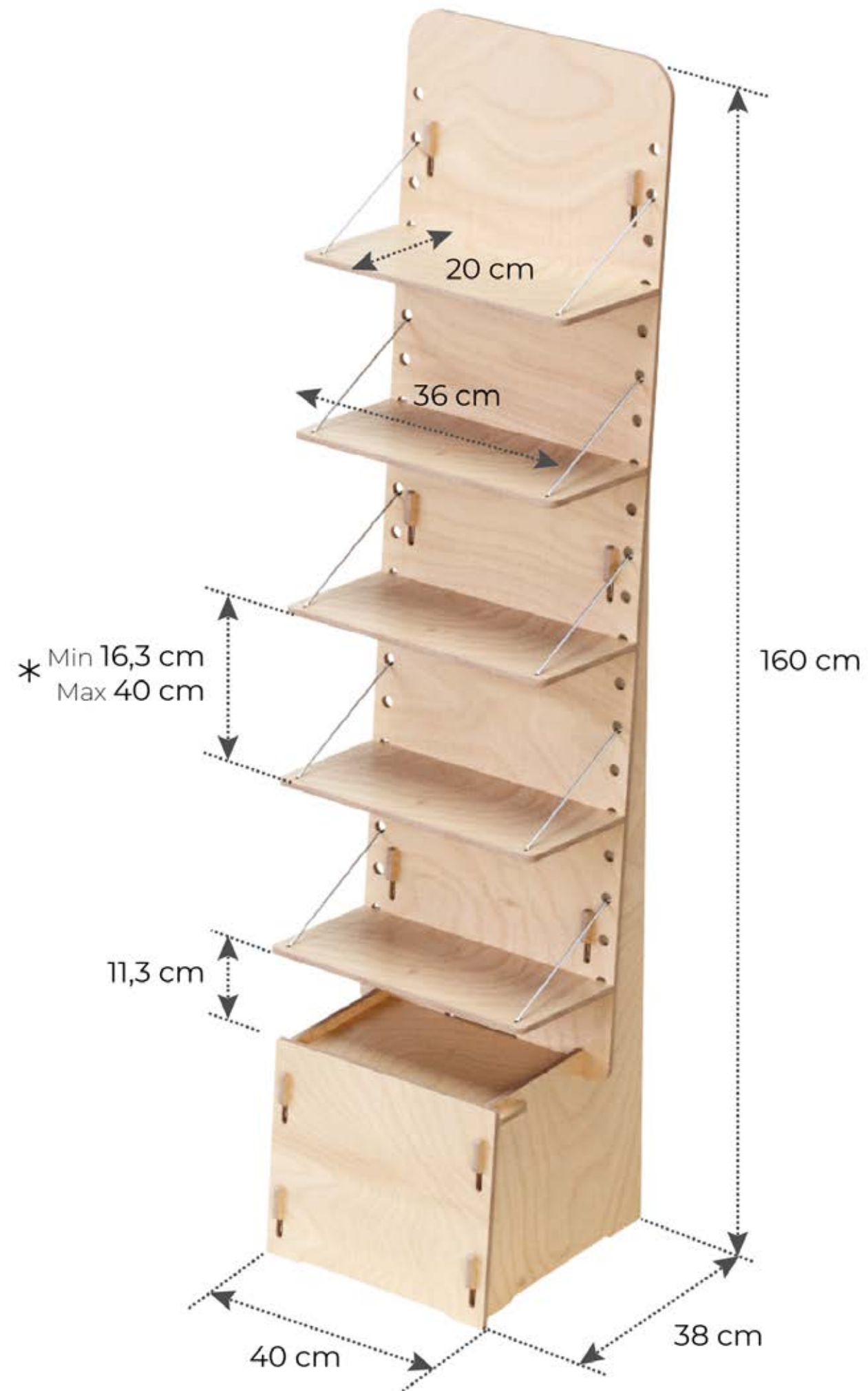

**ARBOR 600**

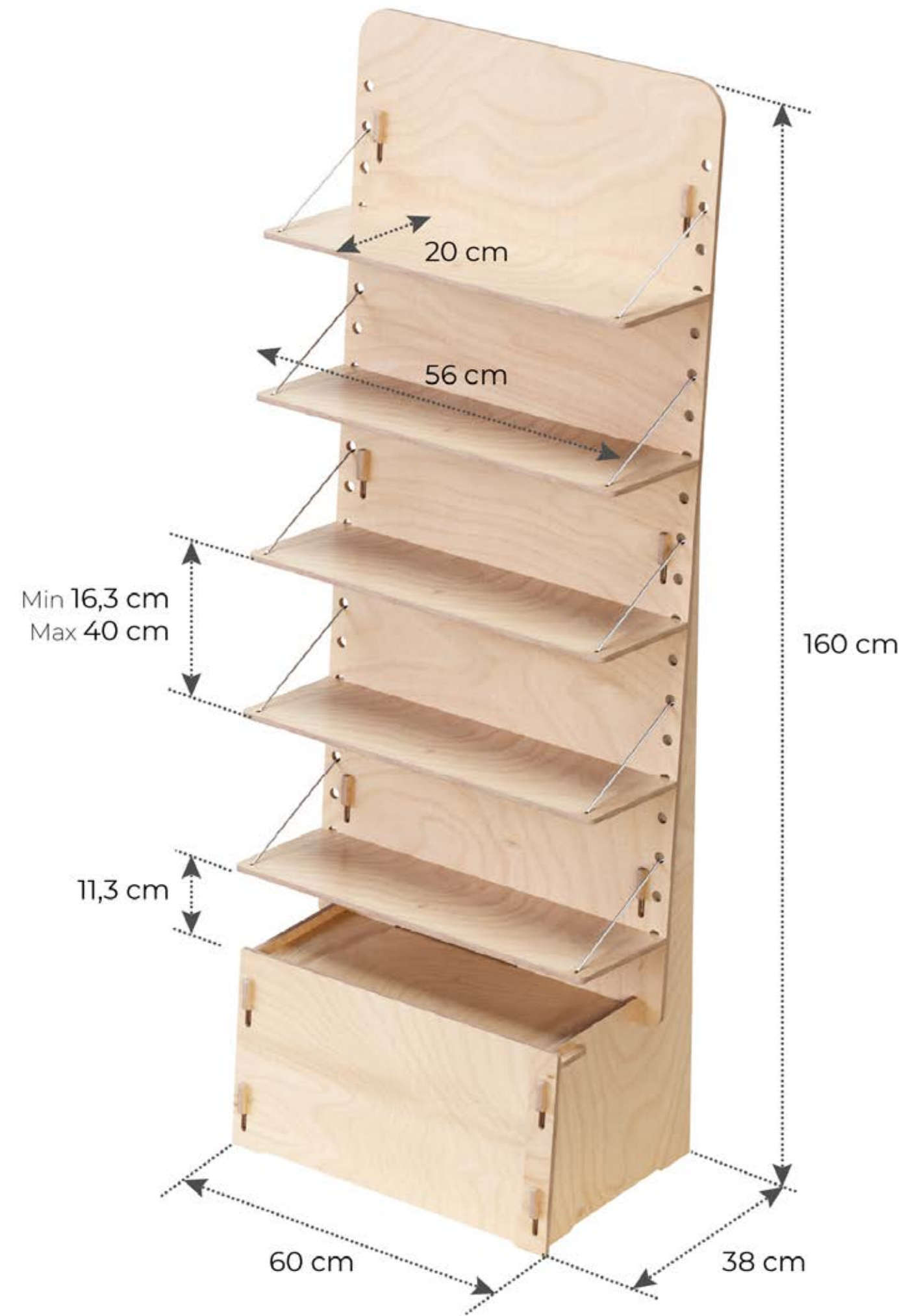

**Material:**

Eucalyptus 9mm

**Weight:**

Arbor 400: 9 kg

Arbor 600: 12 kg

**Package (WxDxH):**

160x45x6

**Customization:**

- Painting
- Graphic printing

So **light**  
So **adjustable**  
So **sustainable**



## Flexi

Featuring movable and tip-up shelves, this stand shows your products from every possible angle.

Crafted from FSC-certified wood sourced from sustainably managed forests, it's an eco-conscious choice for brands looking to showcase their commitment to sustainability.

Its quick interlocking assembly makes setup a breeze, while the lightweight design ensures effortless transportation and placement wherever you need it.

So **light**  
So **adjustable**  
So **sustainable**

**FLEXI 400**

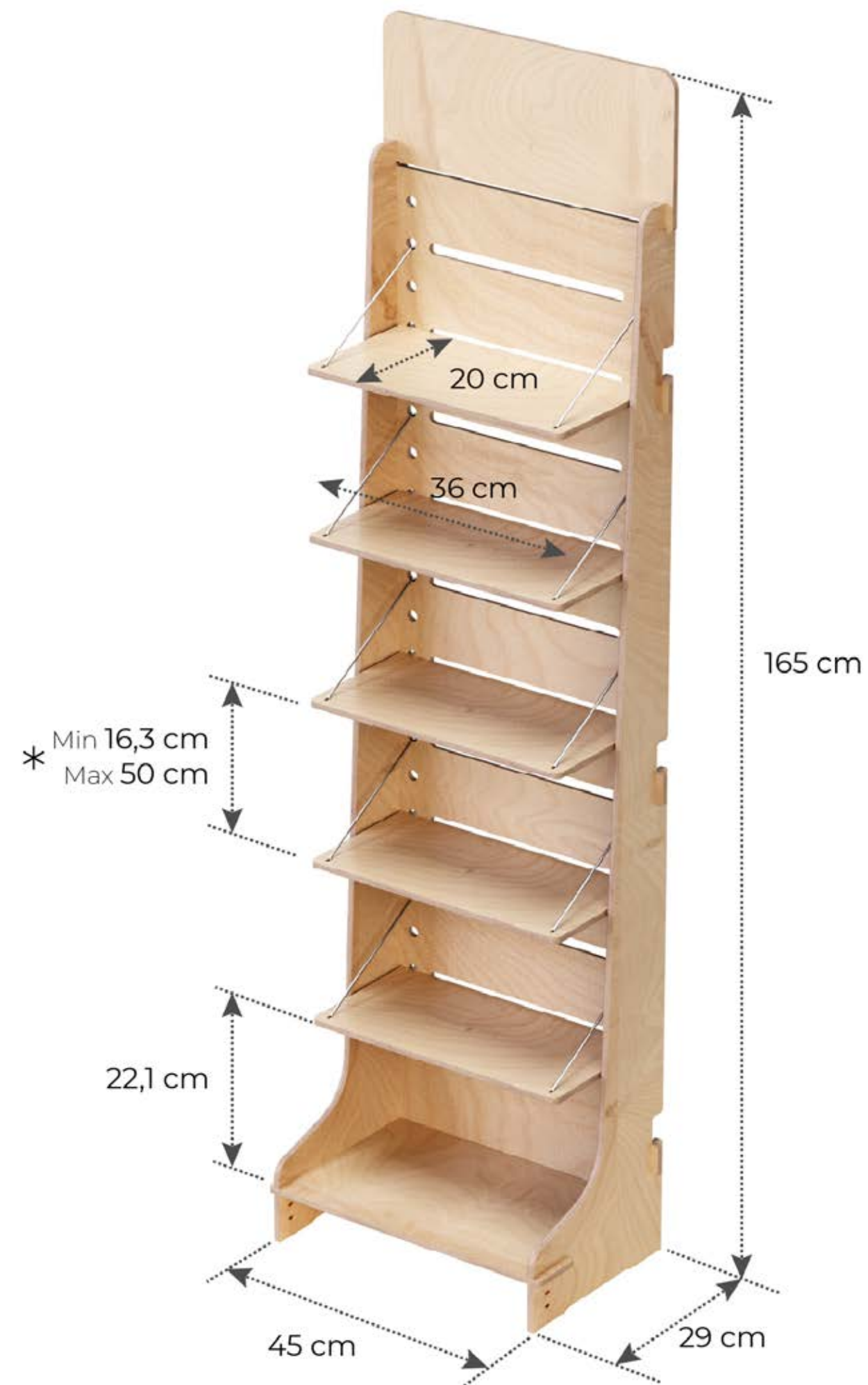

**FLEXI 600**



**Material:**

Eucalyptus 9mm

**Weight:**

Flexi 400: 9 kg

Flexi 600: 12 kg

**Package (WxDxH):**

160x45x6

**Customization:**

- Painting
- Graphic printing

So **light**  
So **adjustable**  
So **sustainable**



## Twin

This sleek, double-sided display is designed to ensure great product visibility from all angles.

Crafted from FSC-certified wood sourced from sustainably managed forests, it offers an eco-friendly and environmentally responsible solution for showcasing and promoting your brand.

With its quick interlocking assembly, setup requires minimal effort, saving you valuable time.

The lightweight construction makes it easy to move and position wherever needed, whether in retail spaces, events, or exhibitions.

Choose a display that combines style, sustainability, and functionality to present your products effectively.

So **light**  
So **adjustable**  
So **sustainable**

**TWIN\_490**



**TWIN\_690**



**TWIN\_MAXI**



**Material:**

Eucalyptus 9mm

**Weight:**

Twin\_490: 7 kg

Twin\_690: 9 kg

Twin\_Maxi: 18 kg

**Package (WxDxH):**

Twin\_490: 120x50x7

Twin\_690: 120x75x7

Twin\_Maxi: 120x120x7

**Customization:**

- Painting
- Graphic printing

So **light**  
So **adjustable**  
So **sustainable**



## Case

Versatile Clothing Display with Innovative Design

This stylish and functional display is perfect for showcasing a wide variety of clothing items. Crafted from FSC-certified wood sourced from sustainably managed forests, it provides an eco-friendly solution for promoting your brand responsibly. With its simple interlocking assembly, this display offers a quick and hassle-free setup, saving you time. Plus, its lightweight construction makes transportation and storage much easier and more efficient—ideal for retail stores, pop-up events, or exhibitions. Choose a display that combines sustainability, modern design, and practicality to highlight your clothing collections.

**Material:**

- Eucalyptus 9 mm
- wheels

**Weight:**

20 kg

**Package (WxDxH):**

150x105x9 cm

**Customization:**

- Painting
- Graphic printing

So **light**  
So **adjustable**  
So **sustainable**

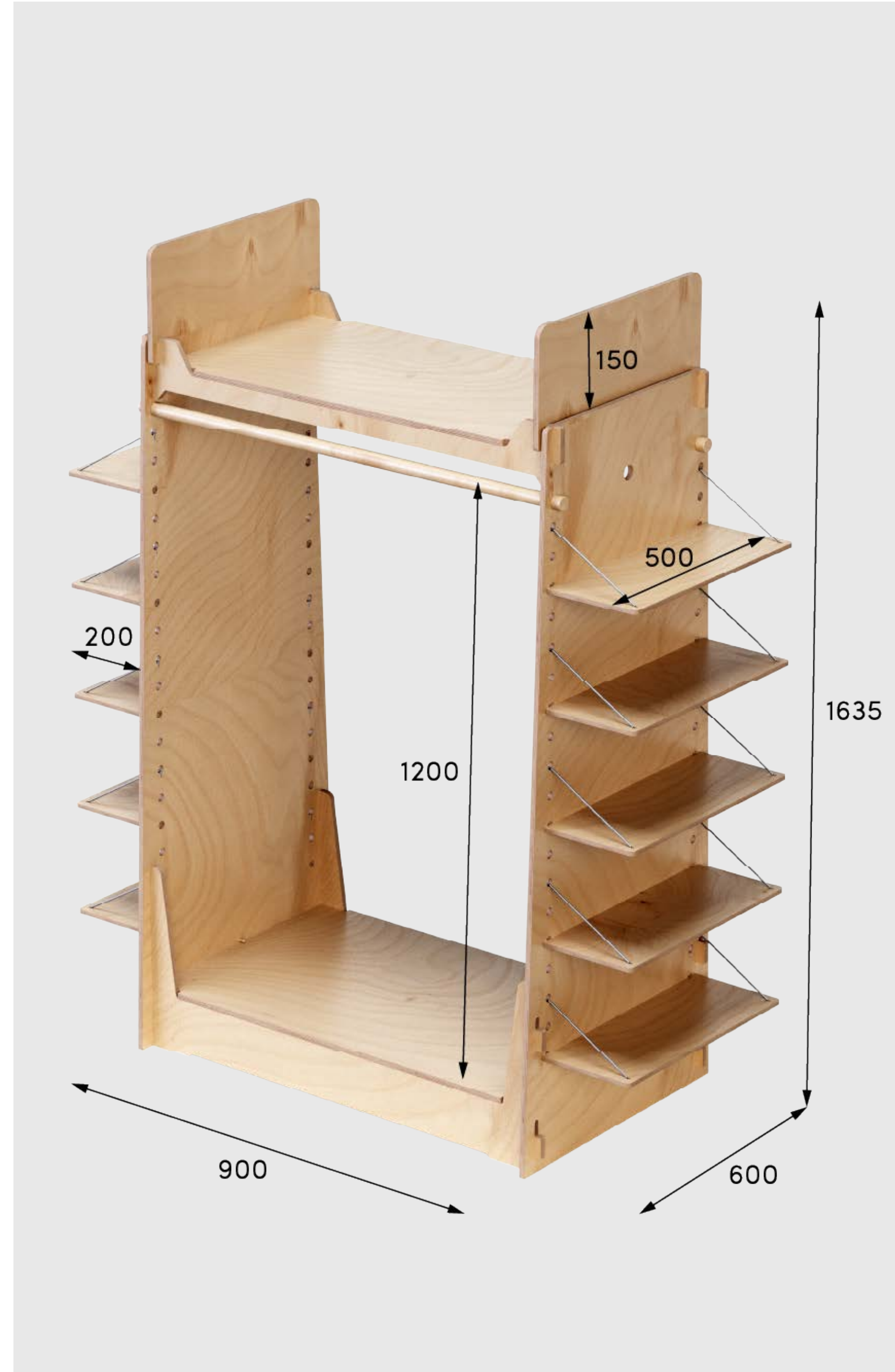

## Double

Featuring a two-sided design for maximum visibility and large capacity, this versatile display is perfect for showcasing a wide range of clothing items.

Crafted from FSCcertified wood sourced from sustainably managed forests, it provides an ecofriendly and responsible solution to promote your brand.

The easy interlocking assembly requires minimal effort, saving you valuable time, while the lightweight wooden construction makes it effortless to transport and store wherever needed. Choose a display that combines sustainability, functionality, and style to enhance your retail space.

**Material:**

- Eucalyptus 9 mm

**Weight:**

23 kg

**Package (WxDxH):**

1700x80x6 cm

**Customization:**

- Painting
- Graphic printing

So **light**  
So **adjustable**  
So **sustainable**



## Oco 800

This clothing display features sleek lines and a minimalist design that offer ample storage space and versatile functionality, making it an ideal choice for retail spaces.

Crafted from FSC-certified wood sourced from sustainably managed forests, it provides an eco-friendly solution for promoting your brand. Its quick interlocking assembly requires minimal effort, saving you valuable time.

Plus, the lightweight wooden construction ensures easy lifting and quick transport wherever needed.

**Material:**

- Eucalyptus 9 mm

**Weight:**

10 kg

**Package (WxDxH):**

160x50x6 cm

**Customization:**

- Painting
- Graphic printing

So **light**  
So **adjustable**  
So **sustainable**

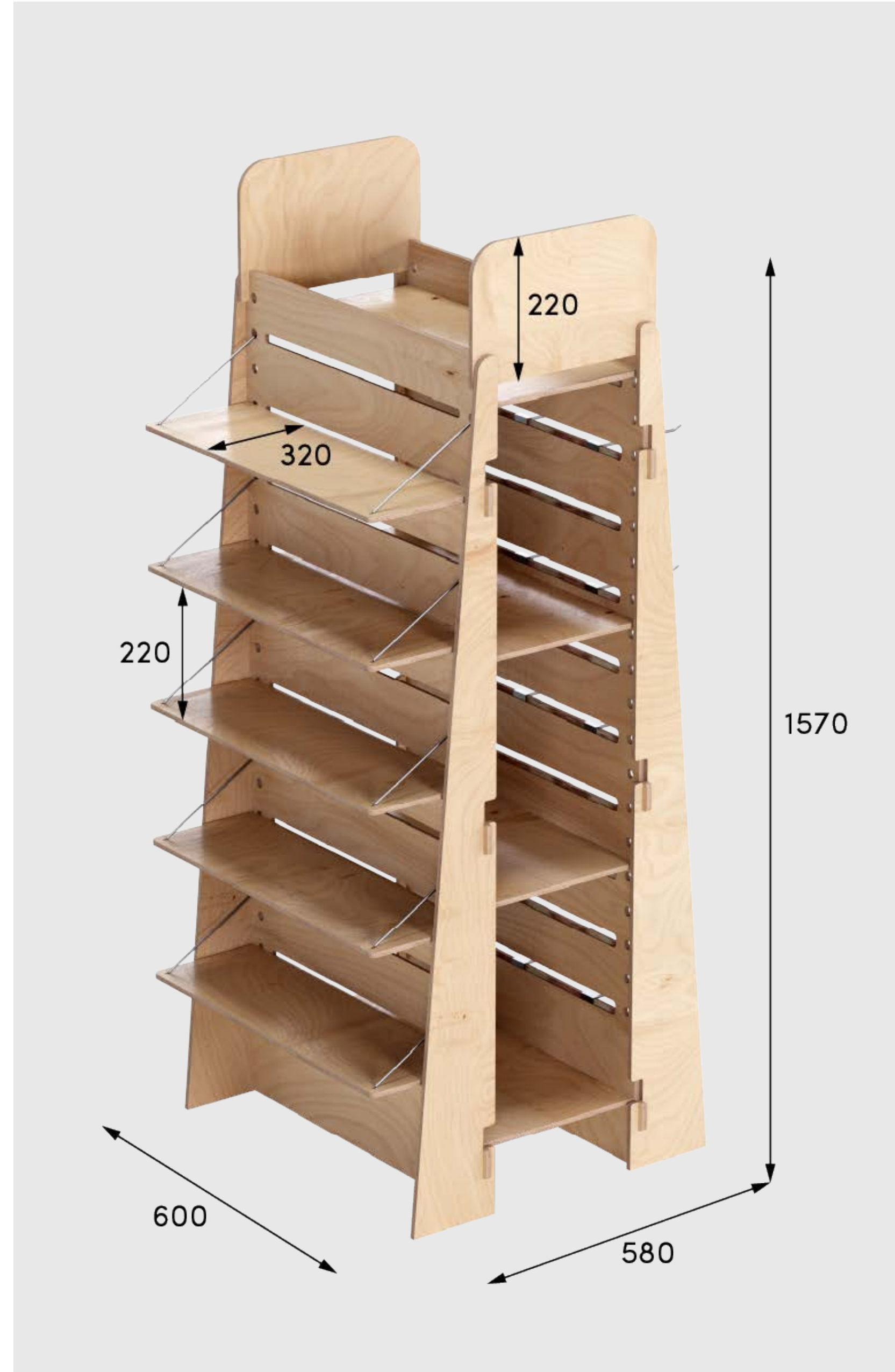

## Pam

This innovative, minimalist clothing display is designed with a double-sided structure to maximize visibility and improve the presentation of your products.

Its versatile design makes it an excellent choice for retail spaces, pop-up shops, or trade shows.

Crafted from FSC-certified wood, it offers a responsible and effective solution for promoting your brand.

Choose a sustainable and stylish display that provides a very effective way to highlight your products!

**Material:**

- Eucalyptus 9 mm
- 15 iron hooks da 20cm

**Weight:**

15 kg

**Package (WxDxH):**

170x80x6 cm

**Customization:**

- Painting
- Graphic printing

So **light**  
So **adjustable**  
So **sustainable**

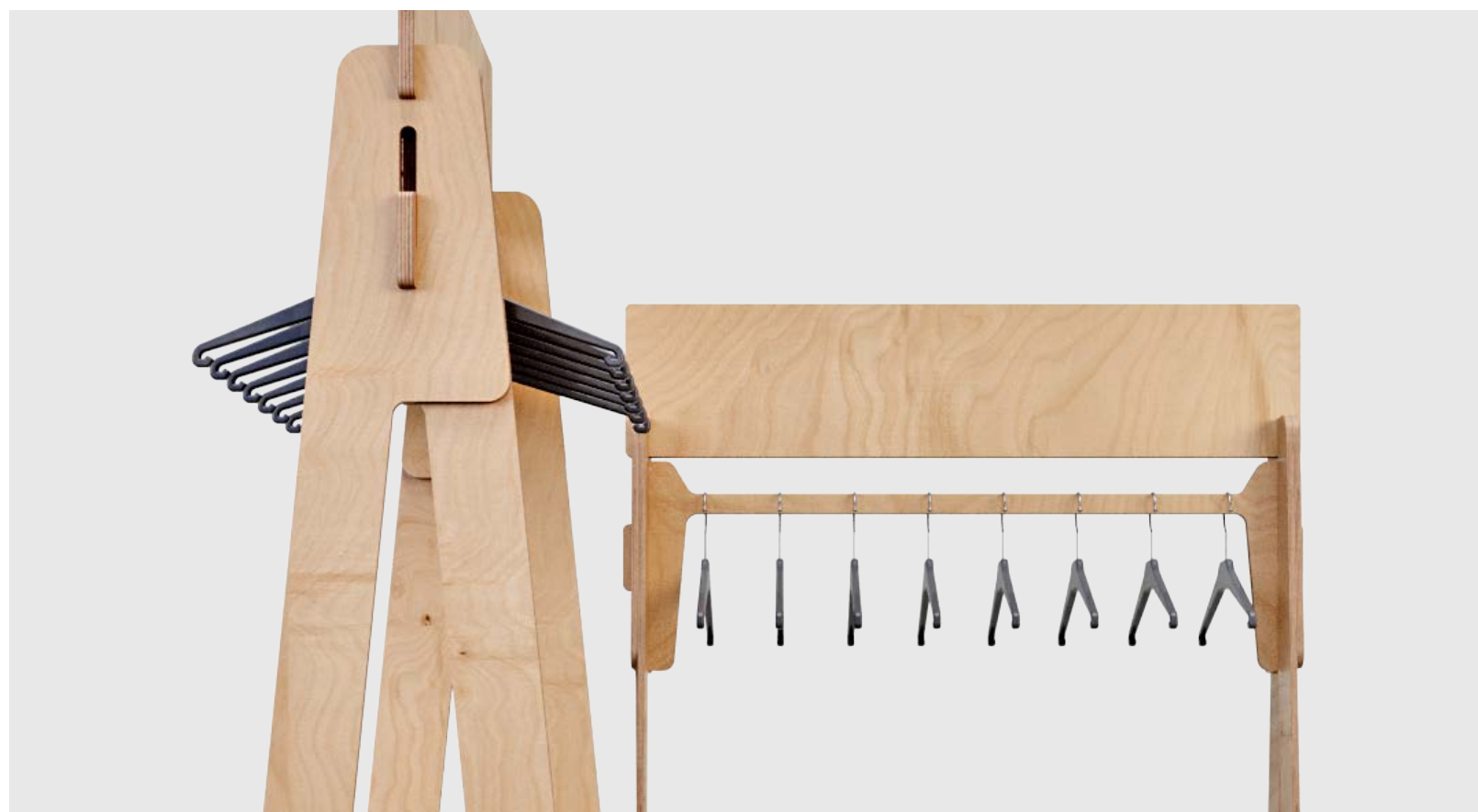

## Velo

This innovative and minimalist clothing display offers excellent capacity and versatility, with dedicated space for hangers to showcase garments in an elegant and organized way.

Crafted from FSC-certified wood sourced from sustainably managed forests, it provides a responsible and eco-friendly way to promote your brand.

The quick interlocking assembly requires minimal effort, saving you valuable time, while its lightweight wooden construction makes it easy to transport and position wherever you need.

So **light**  
So **adjustable**  
So **sustainable**

**VELO**

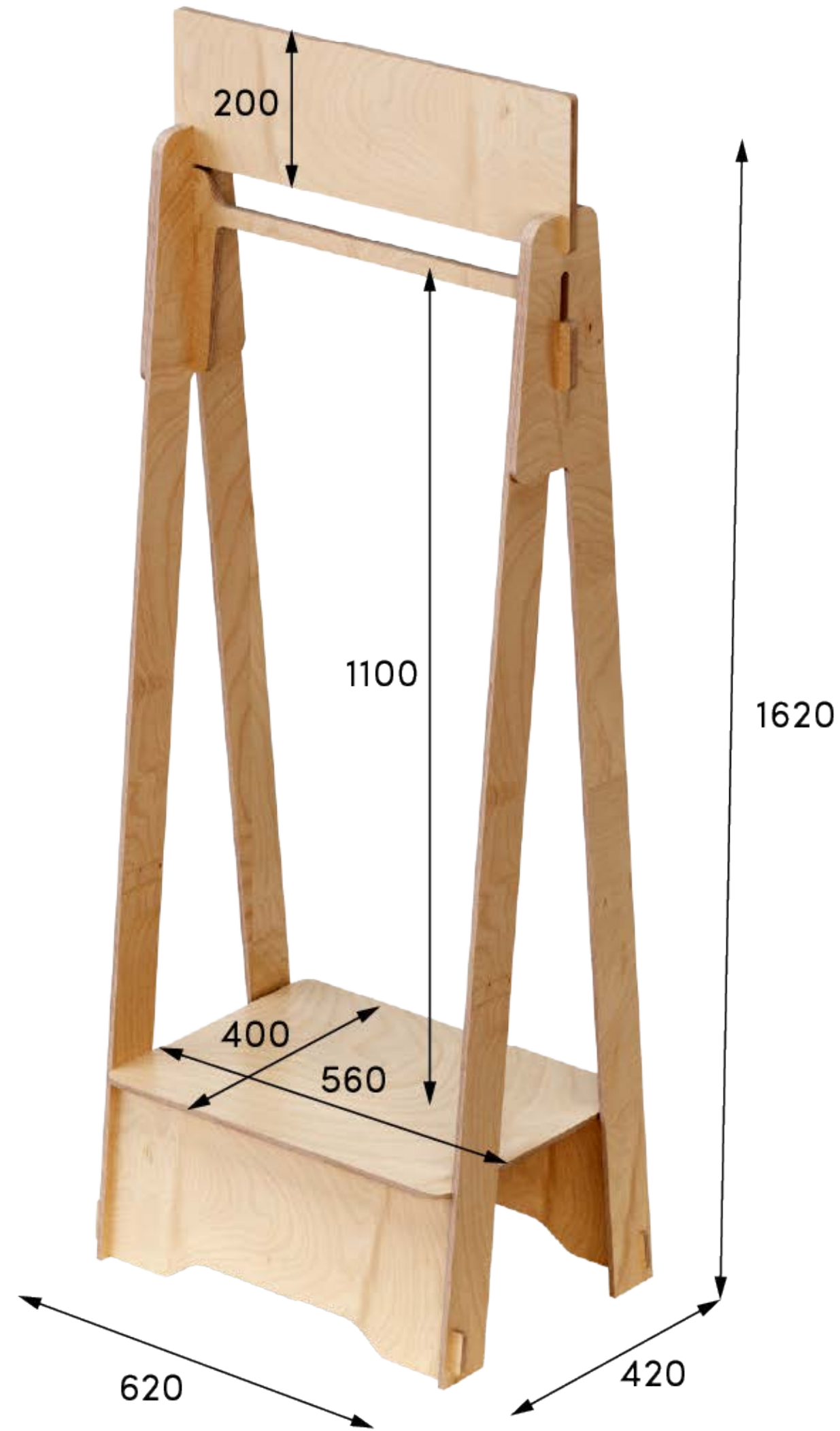

**VELO 800**

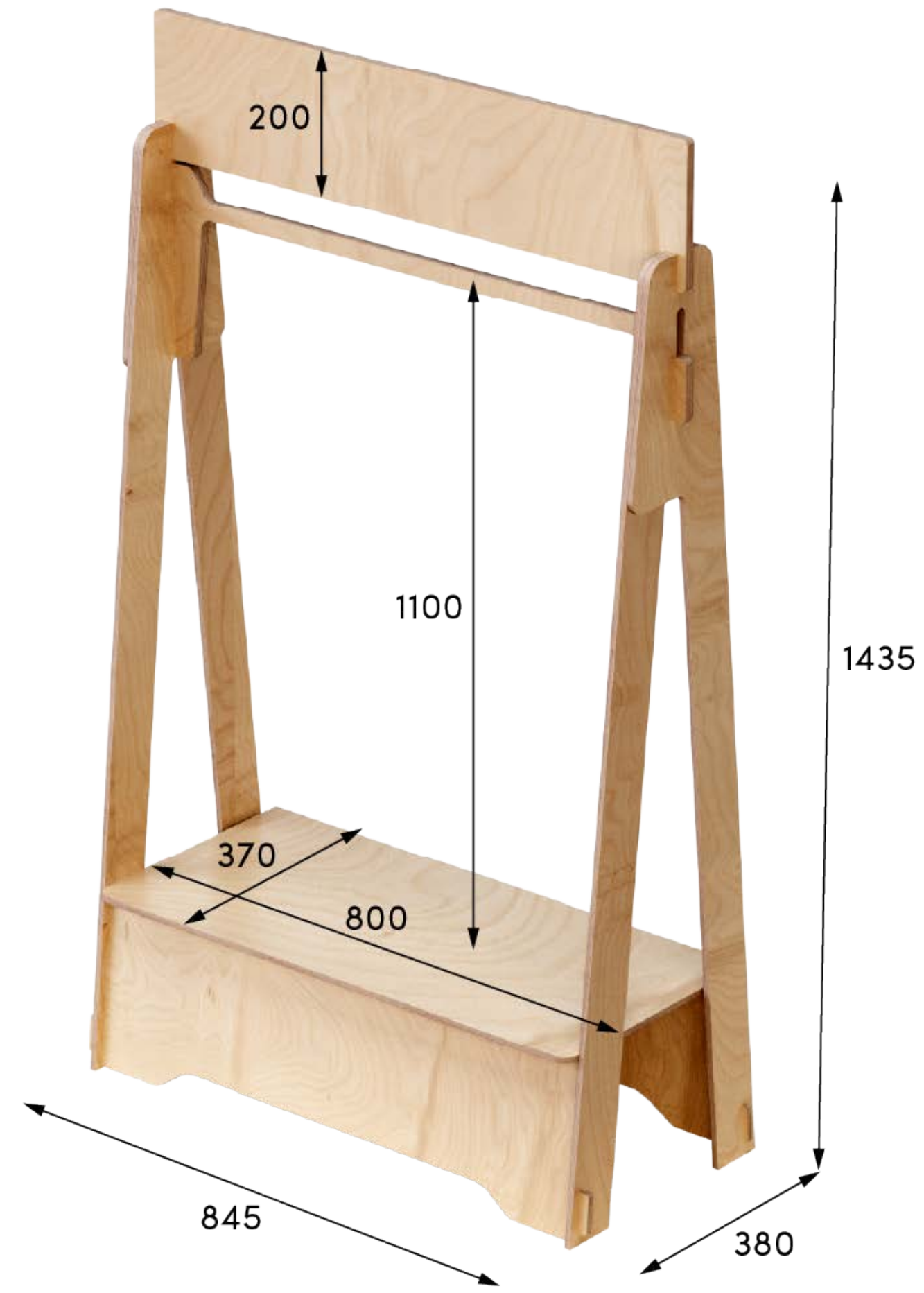

**Material:**

Eucalyptus 9mm

**Weight:**

Velo: 6 kg

Velo 800: 7 kg

Caos 1240.4: 15 kg

Caos 1260.4: 18 kg

**Package (WxDxH):**

160x50x6 cm

**Customization:**

- Painting
- Graphic printing

So **light**  
So **adjustable**  
So **sustainable**

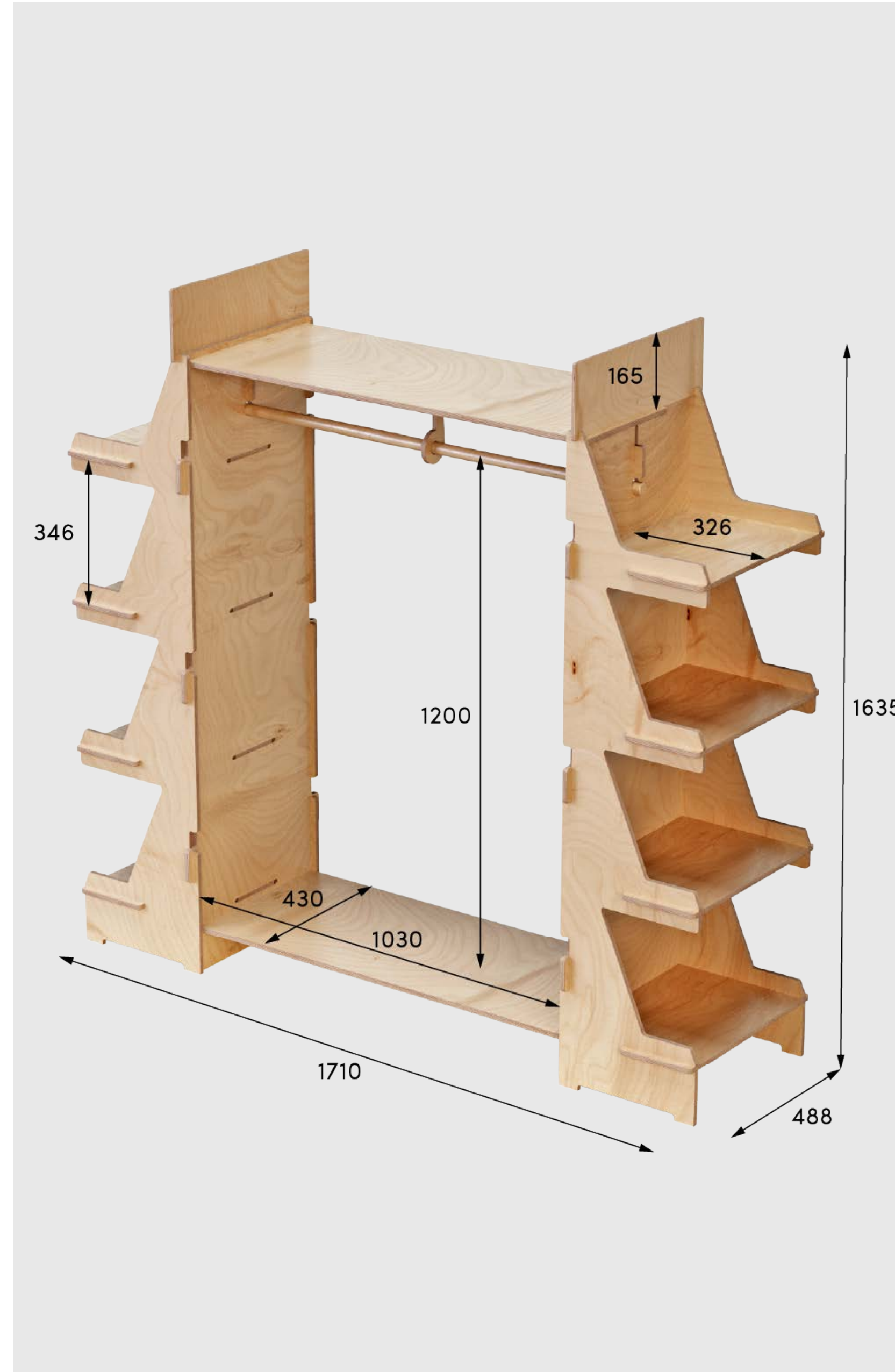

## Venice

This innovative and minimalist clothing display offers great storage capacity and versatility, featuring four shelves on both the right and left sides to maximize your product presentation.

Crafted from FSC-certified wood sourced from sustainably managed forests, it provides a responsible and eco-friendly way to showcase and promote your brand.

With its simple interlocking assembly, this display offers a quick and hassle-free setup, saving you time. Plus, its lightweight wooden construction ensures easy transportation and installation wherever you need it. Elevate your display with a sustainable and stylish solution designed to enhance your product visibility.

**Material:**

- Eucalyptus 12 mm

**Weight:**

33 kg

**Package (WxDxH):**

160x50x10 cm

**Customization:**

- Painting
- Graphic printing

So **light**  
So **adjustable**  
So **sustainable**



## Wally

This versatile display features an innovative design that allows you to showcase your products both on the shelves and bars, making it ideal for a wide range of items.

Crafted from FSC-certified wood sourced from sustainably managed forests, it provides an eco-friendly and responsible solution for presenting and promoting your brand.

With a quick interlocking assembly that requires minimal effort, this display saves you valuable time and reduces your costs, while its lightweight wooden construction makes it easy to transport and set up wherever needed.

So **light**  
So **adjustable**  
So **sustainable**

**WALLY 6**



**WALLY 10**



**Material:**

Eucalyptus 12 - 15 mm

**Weight:**

Wally 6: 12 kg

Wally 10: 16 kg

**Package (WxDxH):**

200x50x5 cm

**Customization:**

- Painting
- Graphic printing

So **light**  
So **adjustable**  
So **sustainable**



## Casattava

Casattava: Award-Winning Multifunctional Design Desk

In 2019, Casattava proudly earned the prestigious Red Dot Design Award for its innovative and multifunctional design.

This versatile desk features two storage containers and a practical bar for hanging objects, making it both a functional workspace and a stylish display unit.

Plus, the lightweight wooden construction ensures easy lifting and quick transport wherever needed.

**Material:**

- Eucalyptus 4 - 9 - 15 mm
- Piano verniciato trasparente

**Weight:**

13 kg

**Package (WxDxH):**

127x62x10 cm

**Customization:**

- Painting
- Graphic printing

So **light**  
So **adjustable**  
So **sustainable**



## Flower Table

This island display is designed with two spacious shelves, making it perfect for florist shops that need to showcase their plant pots.

The top shelf accommodates large vases up to 60-70 cm tall, while the lower shelf provides ample space for accessories, small plants, or decorative items.

This island display can complement any store aesthetic and its no-tool setup provides an easy and solid installation on hard surfaces or in the ground.

**Material:**

- Eucalyptus 12 mm

**Weight:**

9 kg

**Package (WxDxH):**

160x80x8 cm

**Customization:**

- Painting
- Graphic printing

So **light**  
So **adjustable**  
So **sustainable**



## Island XL

This island display offers a large display surface on all four sides, making it the perfect solution for creating proactive 360-degree product views.

Ideal for placing in the middle of the store or as a corner display, it enhances visibility and encourages customer interaction.

It's fully customizable and it can adapt to the new market requirements and situations.

**Material:**

- Eucalyptus 12 mm

**Weight:**

32 kg

**Package (WxDxH):**

110x110x8 cm

**Customization:**

- Painting
- Graphic printing

So **light**  
So **adjustable**  
So **sustainable**



## Play

This display table is the perfect solution for product demonstrations, offering both functionality and style.

Crafted from FSC-certified wood sourced from sustainably managed forests, it provides an environmentally responsible way to promote your brand.

Whether you're presenting at a trade show, setting up a pop-up shop, or enhancing your retail space, this table offers a sleek and practical display solution that reflects your commitment to sustainability.

**Material:**

- Eucalyptus 9 - 18 mm

**Weight:**

16 kg

**Package (WxDxH):**

120x70x6 cm

**Customization:**

- Painting
- Graphic printing

So **light**  
So **adjustable**  
So **sustainable**

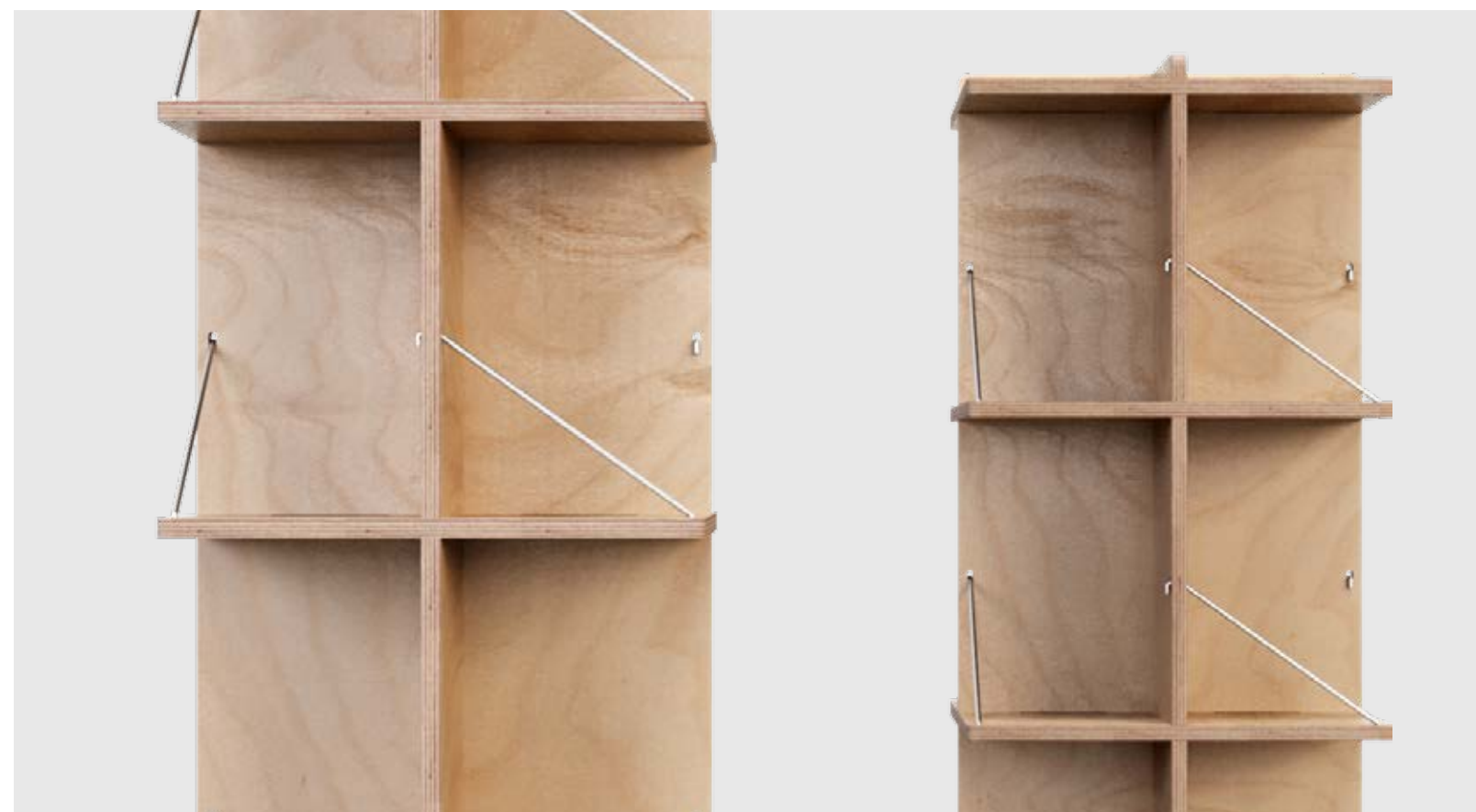

## Avo

Featuring an innovative, rotatable design, this display is the perfect choice for showcasing books and other stationery products like greeting cards and planners.

### Key Features:

- 360-Degree Visibility: The rotating function ensures easy access to all displayed items
- Versatile Use: Perfect for bookstores, stationery shops, or gift stores
- Sustainable Construction: Made from FSC-certified wood sourced from sustainably managed forests
- Effortless Assembly: The quick interlocking system saves valuable time
- Lightweight and Portable: Easy transport and storage on the site

So **light**  
So **adjustable**  
So **sustainable**

**AVO**

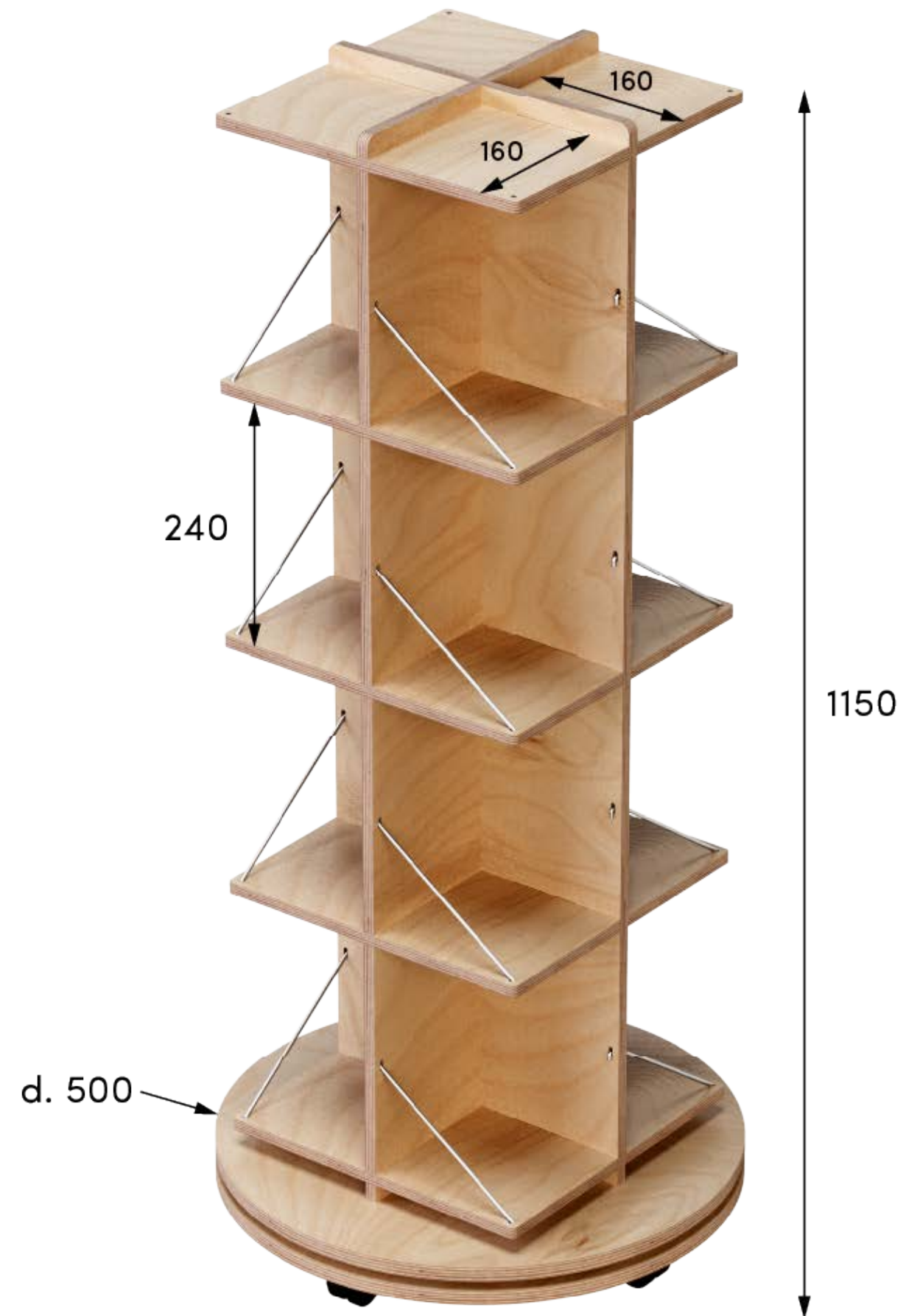

**AVO MAX**

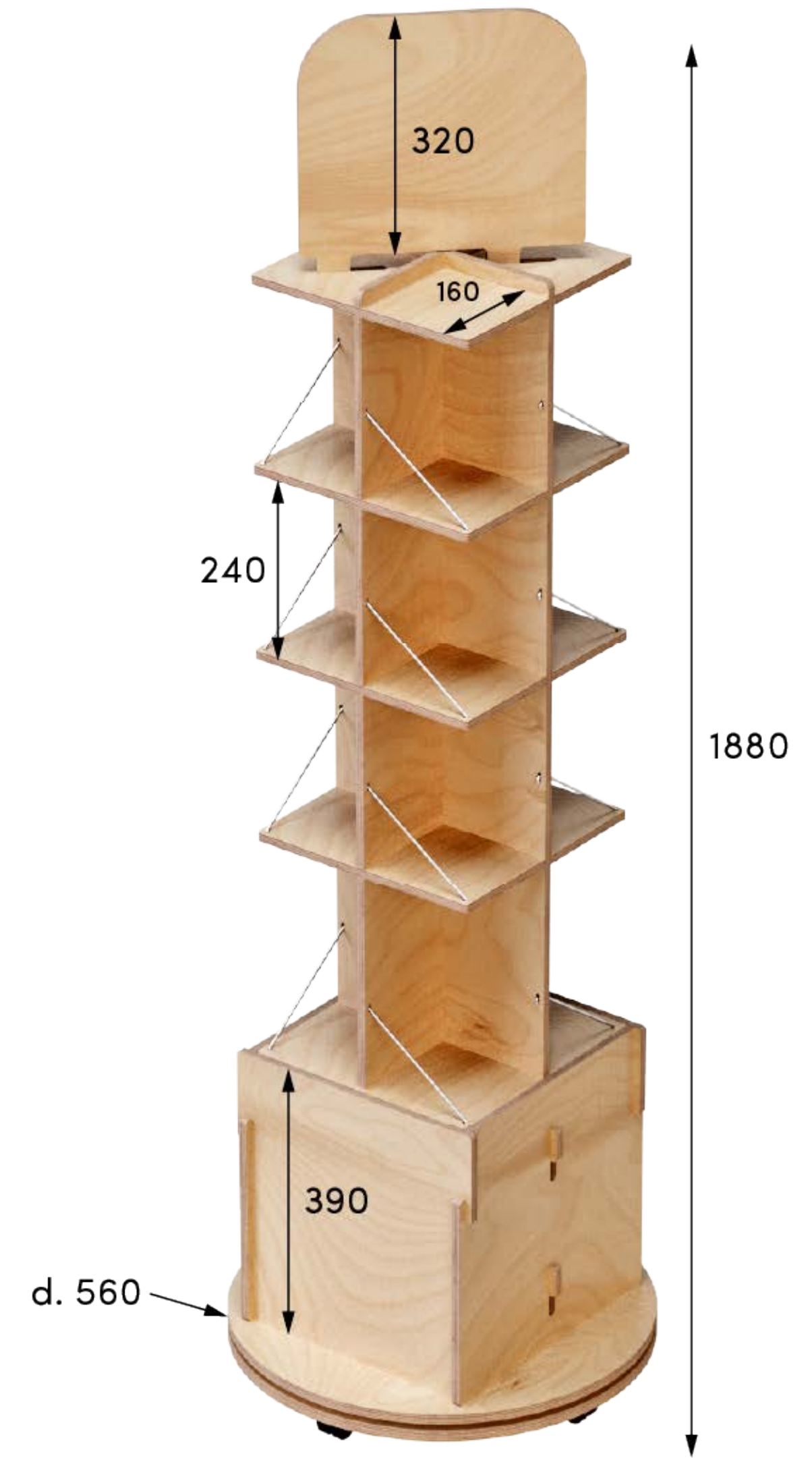

**Material:**

- Eucalyptus 12 - 15 mm
- 4 wheels

**Weight:**

- Avo: 12 kg
- Avo Max: 19 kg

**Package (WxDxH):**

- Avo: 120x60x10
- Avo Max: 160x60x10

**Customization:**

- Painting
- Graphic printing

So **light**  
So **adjustable**  
So **sustainable**

# CUSTOMER REVIEWS

"The willingness to listen and the delivery of quality products enriched by a dedicated personal service and excellent construction and industrialization of the goods have made Esposit a supplier with whom it is possible to work very well."

**PLAYWOOD**  
*Managing Director*

"I found Esposit to be a very professional, precise and punctual company. They supported us with a continuous assistance service and followed us in all the design steps. We can consider ourselves very satisfied."

**JURATOYS ITALIA**  
*Marketing Manager*

"Esposit has proven to be a key supplier in the development of our wooden displays with wheels. Together we have identified the optimized dimensions of the supports, the layout, the best display method for our products and also the best packaging solution to preserve the product and minimize shipping costs."

**HERBAL PRODUCTS**

"Esposit offered us a 360-degree service. Reliability, quality and availability combined with a high attention to detail, are the qualities that we appreciated most. We can consider ourselves very satisfied with the result obtained."

**FERRERO**  
*Trade Marketing Manager*



So **light**  
So **adjustable**  
So **sustainable**